

40G QSFP+ Passive Direct Attach Copper Twinax Cable Specification

1 Description :

QSFP+ (Quad Small Form factor Pluggable) Direct Copper Cable Assemblies are designed for Infiniband 10 Gigabit Ethernet and 40 Gigabit Ethernet applications. These cable assemblies provide four channels of data in one pluggable interface. Each channel is capable of transferring data at 10Gbps and supports a total of 40 Gbps data rate. And meet all IBTA, QSFP MSA and SFF-8436 ,Infiniband QDR specification requirements. Compare with fiber optical cable assemblies, QSFP+ direct copper cable provide a cost-effective solution in data centre short reach interconnects applications.

2 Features:

- Hot-plug swappable
- 3X Port Density over SFP / SFP+
- Optimized NEXT & Return Loss
- Low cost and low power solution compared to fiber optical cable
- Compliant with QSFP+ MSA and SFF-8436
- Compliant with IEEE 802.3ba/ Infiniband QDR specifications
 - Enhanced EMI/EMC performance
 - Supports serial ID functionality thru EEPROM
- Passive cable assembly supports distances up to 7 meters

- 30AWG to 24AWG cable sizes available
- RoHS compliant and Halogen-Free option available

3 Applications :

- Switches / Routers / HBAs/SAN,NIC cards
 - Server & Storage Devices
 - Data Center Networking
- High Performance Compute
 - Fiber Channel
 - InfiniBand QDR/DDR
 - 40Gbs Ethernet

4 Outline drawing :

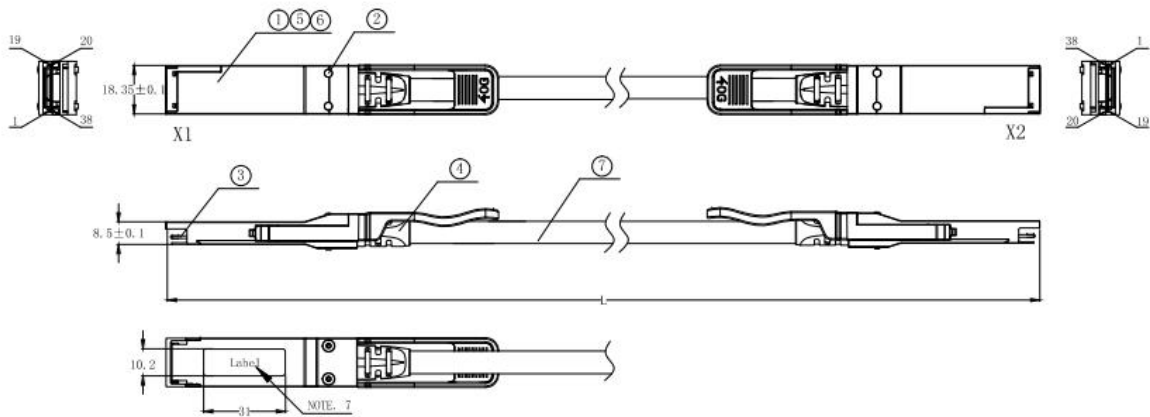

5 Wiring Diagram :

X1	X2	REMARKS	X1	X2	REMARKS
18(RX1-)	37(TX1-)	pair	37(TX1-)	18(RX1-)	pair
17(RX1+)	36(TX1+)		36(TX1+)	17(RX1+)	
15(RX3-)	34(TX3-)	pair	34(TX3-)	15(RX3-)	pair
14(RX3+)	33(TX3+)		33(TX3+)	14(RX3+)	
6 (TX4+)	25(RX4+)	pair	25(RX4+)	6 (TX4+)	pair
5 (TX4-)	24(RX4-)		24(RX4-)	5 (TX4-)	
3 (TX2+)	22(RX2+)	pair	22(RX2+)	3 (TX2+)	pair
2 (TX2-)	21(RX2-)		21(RX2-)	2 (TX2-)	
1, 4, 7, 13, 16, 19, 20, 23, 26, 32, 35, 38	1, 4, 7, 13, 16, 19, 20, 23, 26, 32, 35, 38	GND	8, 9, 10, 11, 12, 27, 28, 29, 30, 31	8, 9, 10, 11, 12, 27, 28, 29, 30, 31	EEPROM point at both ends

6 Electrical Performance :

6.1 Signal Integrity

(ITEM)		(REQUIREMENT)				(TEST CONDITION)	
(Differential Impedance)	Cable Impedance	100±5Ω				Rise time of 35ps (20 % - 80 %).	
	Paddle Card Impedance	100±10Ω					
	Cable Termination Impedance	100±15Ω					
[Differential (Input/Output)Return loss S _{DD11} /S _{DD22}]		≤-10dB				10MHz≤f≤5GHz	
[Differential Insertion Loss (S _{DD21} Max.)]		(Differential InsertionLoss Max. For TPa to TPb Excluding Test fixture)				10MHz≤f≤19GHz	
		F	600Mhz	1.25Ghz	2.5Ghz		5.0Ghz
		AWG					
	30(1 m)	≥-3.0dB	≥-4.0dB	≥-5.5dB	≥-8.0dB		

	28(3 m)	≥-5.0dB	≥-6.5dB	≥-9.5dB	≥-14.0dB	
	26(5 m)	≥-6.0dB	≥-8.0dB	≥-11.0dB	≥-16.0dB	
	24(10 m)					
[Insertion Loss Deviation]	-0.7-0.2*10 ⁻³ f ≤ ILD ≤ 0.7+0.2*10 ⁻³ f (f is the frequency in MHz)					10MHz≤f≤5G Hz
[MDNEXT(multiple disturber near-end crosstalk)]	≥26dB					10MHz≤f≤5G Hz

6.2 Other Electrical Performance

(ITEM)	(REQUIREMENT)	(TEST CONDITON)
[Low Level Contact Resistance]	80milliohms Max. From initial.	EIA-364-23:Apply a maximum voltage of 20mV And a current of 100 mA.
Insulation Resistance	10Mohm(Min.)	EIA364-21:AC 300V 1minute
[Dielectric Withstanding Voltage]	NO disruptive discharge.	EIA-364-20:Apply a voltage of 300 VDC for 1minute between adjacent terminals And between adjacent terminals and ground.

7 Environment Performance

(ITEM)	(REQUIREMENT)	(TEST CONDITON)
[Operating Temp. Range]	-20°C to +75°C	Cable operating temperature range.
[Storage Temp. Range (in packed condition)]	-20°C to +55°C	Cable storage temperature range in packed condition.
[Thermal Cycling Non-Powered]	No evidence of physical damage	EIA-364-32D, Method A, -25 to 90C, 100 cycles, 15 min. dwells
[Salt Spraying]	48 hours salt spraying after shell corrosive area less than 5%.	EIA-364-26
Mixed Flowing Gas	Pass electrical tests per 3.1 after stressing. (For connector only)	EIA-364-35 Class II,14 days.
Temp. Life	No evidence of physical damage	EIA-364-17C w/ RH, Damp heat 90°C at 85% RH for 500 hours then return to ambient
Cable Cold Bend	4H, No evidence of physical damage	Condition: -20°C±2°C, mandrel diameter is 6 times the cable diameter.

8 Mechanical and Physical Characteristics

(ITEM)	(REQUIREMENT)	(TEST CONDITON)
Vibration	Pass electrical tests per 3.1 after stressing.	Clamp & vibrate per EIA-364-28E, TC-VII, test condition letter – D, 15 minutes in X, Y & Z axis.
Cable Flex	No evidence of physical damage	Flex cable 180° for 20 cycles ($\pm 90^\circ$ from nominal position) at 12 cycles per minute with a 1.0kg load applied to the cable jacket. Flex in the boot area 90° in each direction from vertical. Per EIA-364-41C
Cable Plug Retention in Cage	90N Min. No evidence of physical damage	Force to be applied axially with no damage to cage. Per SFF 8661 Rev 2.1 Pull on cable jacket approximately 1 ft behind cable plug. No functional damage to cable plug below 90N. Per SFF-8432 Rev 5.0
Cable Retention in Plug	90N Min. No evidence of physical damage	Cable plug is fixtured with the bulk cable hanging vertically. A 90N axial load is applied (gradually) to the cable jacket and held for 1 minute. Per EIA-364-38B
Mechanical Shock	Pass electrical tests Per 3.1 after stressing.	Clamp and shock per EIA-364-27B, TC-G,3 times in 6 directions, 100g, 6ms.
Cable Plug Insertion	40N Max.	Per SFF-8436 Rev 5.4.1.
Cable plug Extraction	30N Max.	Place axial load on de-latch to de-latch plug.Per SFF-8436 Rev 5.4.1.
Durability	50 cycles, No evidence of physical damage	EIA-364-09, perform plug & unplug cycles: Plug and receptacle mate rate: 250times/hour. 50times for module (CONNECTOR TO PCB)