

# 200Gbps QSFP56 To 4x 50G SFP56

## Passive Direct Attach Copper Breakout Cable Specification

### 1 Description :

200G QSFP56 passive cable assembly products, based on 4X50G or 4X56G structure, this product can well meet the needs of next-generation 200G switches, servers, routers and other product applications.

QSFP56 cable assembly adopts optimized design to reduce crosstalk and insertion loss, has excellent signal integrity, and fully complies with the next-generation 200G Ethernet and InfiniBand HDR standards.

SFP56 is based on the same shape as SFP28, supports NRZ/PAM4 transmission, can provide 56Gb/s error-free transmission, and can be used in high-density 56G Ethernet switches and network interfaces to promote server connections in data centers.

200G QSFP56 To 4x50G SFP56 supports the interconnection of two interface devices, with a single channel transmission rate of 56Gbps.



## 2 Features

- Comply with SFF-8636
- Complies with Ethernet IEEE802.3bj/IEEE 802.3cd
- Support serial ID function through EEPROM
- Support hot swap, low crosstalk, low power consumption
- Support the maximum distance of 3 meters
- Operating temperature range: 0°C to 70°C
- RoHS compliant
- Four electrical interface transmits up to 28Gbps NRZ or 56Gbps PAM4

## 3 Applications :

10G/40G /100g/200 Ethernet

Infiniband SDR, DDR, QDR, FDR, EDR, HDR

Switch

Router

Data center

Cloud server

#### 4 Outline drawing :

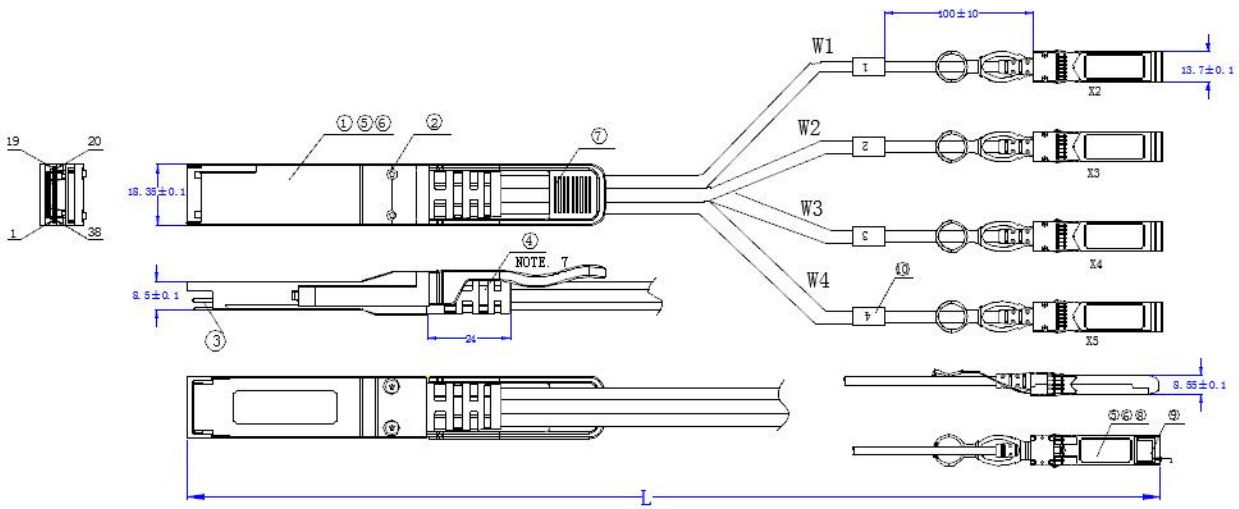

26AWG QSFP56:

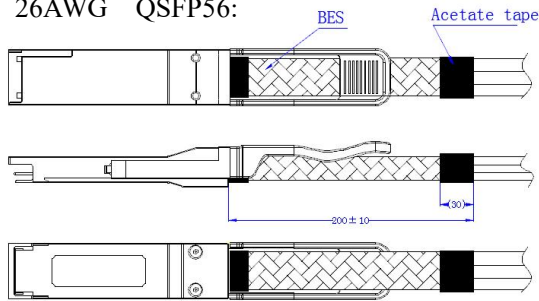

#### 5 Wiring Diagram:

wire	Starting signal	Starting	End	End signal
W1	RX1+	X1. 17	X2. 18	TX1+
	RX1-	X1. 18	X2. 19	TX1-
	GND	X1. 19	X2. 20	GND
	TX1+	X1. 36	X2. 13	RX1+
	TX1-	X1. 37	X2. 12	RX1-
	GND	X1. 38	X2. 14	GND
W2	GND	X1. 20	X3. 20	GND
	RX2-	X1. 21	X3. 19	TX2-
	RX2+	X1. 22	X3. 18	TX2+
	GND	X1. 1	X3. 14	GND
	TX2-	X1. 2	X3. 12	RX2-
	TX2+	X1. 3	X3. 13	RX2+

wire	Starting signal	Starting	End	End signal
W3	RX3+	X1. 14	X4. 18	TX3+
	RX3-	X1. 15	X4. 19	TX3-
	GND	X1. 16	X4. 20	GND
	TX3+	X1. 33	X4. 13	RX3+
	TX3-	X1. 34	X4. 12	RX3-
	GND	X1. 35	X4. 14	GND
W4	GND	X1. 23	X5. 20	GND
	RX4-	X1. 24	X5. 19	TX4-
	RX4+	X1. 25	X5. 18	TX4+
	GND	X1. 4	X5. 14	GND
	TX4-	X1. 5	X5. 12	RX4-
	TX4+	X1. 6	X5. 13	RX4+

## 6 Electrical Performance:

### 6.1 (Signal Integrity)

(ITEM)		(REQUIREMENT)	(TEST CONDITION)																																			
(Differential Impedance)	Cable Impedance	105+5/-10Ω	Rise time of 25ps (20 % - 80 %).																																			
	Paddle Card Impedance	100±10Ω																																				
	Cable Termination Impedance	100±15Ω																																				
[Differential (Input/Output)Return loss S <sub>DD11</sub> /S <sub>DD22</sub> ]	$\text{Return\_loss}(f) \geq \left\{ \begin{array}{ll} 16.5-2\sqrt{f} & 0.05 \leq f < 4.1 \\ 10.66-14\log_{10}(f/5.5) & 4.1 \leq f \leq 19 \end{array} \right\}$ Where f is the frequency in GHz Return loss(f) is the return loss at frequency f	10MHz≤f≤19GHz																																				
[Differential to common-mode (Input/Output)Return loss S <sub>CD11</sub> /S <sub>CD22</sub> ]	$\text{Return\_loss}(f) \geq \left\{ \begin{array}{ll} 22-(20/25.78)f & 0.01 \leq f < 12.89 \\ 15-(6/25.78)f & 12.89 \leq f \leq 19 \end{array} \right\}$ Where f is the frequency in GHz Return_loss(f) is the Differential to common-mode return loss at frequency f	10MHz≤f≤19GHz																																				
[Common-mode to Common-mode (Input/Output)Return loss S <sub>CC11</sub> /S <sub>CC22</sub> ]	$\text{Return\_loss}(f) \geq 2\text{dB} \quad 0.2 \leq f \leq 19$ Where f is the frequency in GHz Return_loss(f) is the common-mode to common-mode return loss at frequency f	10MHz≤f≤19GHz																																				
[Differential Insertion Loss (S <sub>DD21</sub> Max.)]	(Differential InsertionLoss Max. For TPa to TPb Excluding Test fixture ) <table border="1" style="width:100%; text-align:center;"> <thead> <tr> <th>F AWG</th> <th>1.25GHz</th> <th>2.5GHz</th> <th>5.0GHz</th> <th>7.0GHz</th> <th>10Ghz</th> <th>12.89Ghz</th> </tr> </thead> <tbody> <tr> <td>30(1m) Max.</td> <td>4.5dB</td> <td>5.4dB</td> <td>6.3dB</td> <td>7.5dB</td> <td>8.5dB</td> <td>10.5dB</td> </tr> <tr> <td>30/28(3 m)Max.</td> <td>7.5dB</td> <td>9.5dB</td> <td>12.2dB</td> <td>14.8dB</td> <td>18.0dB</td> <td>21.5dB</td> </tr> <tr> <td>26(3m) Max.</td> <td>5.7dB</td> <td>7.2dB</td> <td>9.9 dB</td> <td>11.9dB</td> <td>14.1dB</td> <td>16.5dB</td> </tr> <tr> <td>26/25(5 m)Max.</td> <td>7.8dB</td> <td>10.0dB</td> <td>13.5dB</td> <td>16.0dB</td> <td>19.0dB</td> <td>22.0dB</td> </tr> </tbody> </table>		F AWG	1.25GHz	2.5GHz	5.0GHz	7.0GHz	10Ghz	12.89Ghz	30(1m) Max.	4.5dB	5.4dB	6.3dB	7.5dB	8.5dB	10.5dB	30/28(3 m)Max.	7.5dB	9.5dB	12.2dB	14.8dB	18.0dB	21.5dB	26(3m) Max.	5.7dB	7.2dB	9.9 dB	11.9dB	14.1dB	16.5dB	26/25(5 m)Max.	7.8dB	10.0dB	13.5dB	16.0dB	19.0dB	22.0dB	10MHz≤f≤19GHz
F AWG	1.25GHz	2.5GHz	5.0GHz	7.0GHz	10Ghz	12.89Ghz																																
30(1m) Max.	4.5dB	5.4dB	6.3dB	7.5dB	8.5dB	10.5dB																																
30/28(3 m)Max.	7.5dB	9.5dB	12.2dB	14.8dB	18.0dB	21.5dB																																
26(3m) Max.	5.7dB	7.2dB	9.9 dB	11.9dB	14.1dB	16.5dB																																
26/25(5 m)Max.	7.8dB	10.0dB	13.5dB	16.0dB	19.0dB	22.0dB																																

Differential to common-mode Conversion Loss-Differential Insertion Loss( $S_{CD21}-S_{DD21}$ )	$\text{Conversion\_loss}(f) - \text{IL}(f) \geq \begin{cases} 10 & 0.01 \leq f < 12.89 \\ 27-(29/22)f & 12.89 \leq f < \end{cases}$ <p>Where <math>f</math> is the frequency in GHz  <math>\text{Conversion\_loss}(f)</math> is the cable assembly differential to common-mode conversion loss  <math>\text{IL}(f)</math> is the cable assembly insertion loss</p>	$10\text{MHz} \leq f \leq 19\text{GHz}$
[MDNEXT(multiple disturber near-end crosstalk)]	$\geq 26\text{dB @}12.89\text{GHz}$	$10\text{MHz} \leq f \leq 19\text{GHz}$

## 6.2 (Other Electrical Performance)

(ITEM)	(REQUIREMENT)	(TEST CONDITON)
[Low Level Contact Resistance]	70milliohms Max. From initial.	EIA-364-23:Apply a maximum voltage of 20mV And a current of 100 mA.
Insulation Resistance	10Mohm(Min.)	EIA364-21:AC 300V 1minute
[Dielectric Withstanding Voltage]	NO disruptive discharge.	EIA-364-20:Apply a voltage of 300 VDC for 1minute between adjacent terminals And between adjacent terminals and ground.

## 7 Environment Performance

(ITEM)	(REQUIREMENT)	(TEST CONDITON)
[Operating Temp. Range]	$-20^{\circ}\text{C}$ to $+75^{\circ}\text{C}$	Cable operating temperature range.
[Storage Temp. Range (in packed condition)]	$-40^{\circ}\text{C}$ to $+80^{\circ}\text{C}$	Cable storage temperature range in packed condition.
[Thermal Cycling Non-Powered]	No evidence of physical damage	EIA-364-32D, Method A, $-25$ to $90\text{C}$ , 100 cycles, 15 min. dwells
[Salt Spraying]	48 hours salt spraying after shell corrosive area less than 5%.	EIA-364-26
Mixed Flowing Gas	Pass electrical tests per 3.1 after stressing. (For connector only)	EIA-364-35 Class II, 14 days.
Temp. Life	No evidence of physical damage	EIA-364-17C w/ RH, Damp heat $90^{\circ}\text{C}$ at 85% RH for 500 hours then return to ambient
Cable Cold Bend	4H, No evidence of physical damage	Condition: $-20^{\circ}\text{C} \pm 2^{\circ}\text{C}$ , mandrel diameter is 6 times the cable diameter.

## 8 Mechanical and Physical Characteristics

(ITEM)	REQUIREMENT)	(TEST CONDITON)
Vibration	Pass electrical tests per 3.1 after stressing.	Clamp & vibrate per EIA-364-28E, TC-VII, test condition letter – D, 15 minutes in X, Y & Z axis.
Cable Flex	No evidence of physical damage	Flex cable 180° for 20 cycles ( $\pm 90^\circ$ from nominal position) at 12 cycles per minute with a 1.0kg load applied to the cable jacket. Flex in the boot area 90° in each direction from vertical. Per EIA-364-41C
Cable Plug Retention in Cage	90N Min. No evidence of physical damage	Force to be applied axially with no damage to cage. Per SFF 8661 Rev 2.1 Pull on cable jacket approximately 1 ft behind cable plug. No functional damage to cable plug below 90N. Per SFF-8432 Rev 5.0
Cable Retention in Plug	90N Min. No evidence of physical damage	Cable plug is fixtured with the bulk cable hanging vertically. A 90N axial load is applied (gradually) to the cable jacket and held for 1 minute. Per EIA-364-38B
Mechanical Shock	Pass electrical tests Per 3.1 after stressing.	Clamp and shock per EIA-364-27B, TC-G,3 times in 6 directions, 100g, 6ms.
Cable Plug Insertion	40N Max.(QSFP56) 18N Max.(SFP56)	Per SFF8661 Rev 2.1 Per SFF-8432 Rev 5.0
Cable plug Extraction	30N Max. (QSFP56) 12.5N Max. (SFP56)	Place axial load on de-latch to de-latch plug.Per SFF8661 Rev 2.1 Measure without the aid of any cage kick-out springs. Place axial load on de-latch to de-latch plug. Per SFF-8432 Rev 5.0
Durability	50 cycles, No evidence of physical damage	EIA-364-09, perform plug & unplug cycles: Plug and receptacle mate rate: 250times/hour. 50times for QSFP28/SFP28 module (CONNECTOR TO PCB)