

400Gbps QSFP DD To 4x 100G QSFP56 Passive Direct Attach Copper Breakout Cable Specification

1 Description:

QSFP-DD (Double Density) has eight-channel electrical interfaces, with data transmission rates up to 28Gbps NRZ or 56Gbps PAM4, and total data rates up to 200Gbps or 400Gbps. QSFP-DD connectors and cable assemblies comply with IEEE 802.3bj, InfiniBand EDR and SAS 3.0 specifications, so they are suitable for various next-generation technologies and applications

QSFP56 passive cable assembly products, based on 4X50G or 4X56G structure, can well meet the application requirements of next-generation 200G switches, servers, routers and other products. QSFP56 cable assemblies are optimized to reduce crosstalk and insertion loss, and have good signal integrity, fully complying with the next-generation 200G Ethernet and InfiniBand HDR standards.

2 Product Features

- Comply with SFF-8636&QSFP-DD MSA
- Complies with Ethernet IEEE802.3bj/IEEE 802.3cd
- Support serial ID function through EEPROM
- Support hot swap, low crosstalk, low power consumption
- Support the maximum distance of 3 meters
- Operating temperature range: 0°C to 70°C
- RoHS compliant
- Eight-lane electrical interface transmits up to 28Gbps NRZ or 56Gbps PAM4

3 Applications :

- Telecommunications equipment
 - ◇ Servers
 - ◇ Routers
 - ◇ Switches
 - ◇ Cellular infrastructure
 - ◇ Multi-platform service systems
- Data networking equipment
 - ◇ Servers
 - ◇ Storage

4 Outline drawing:

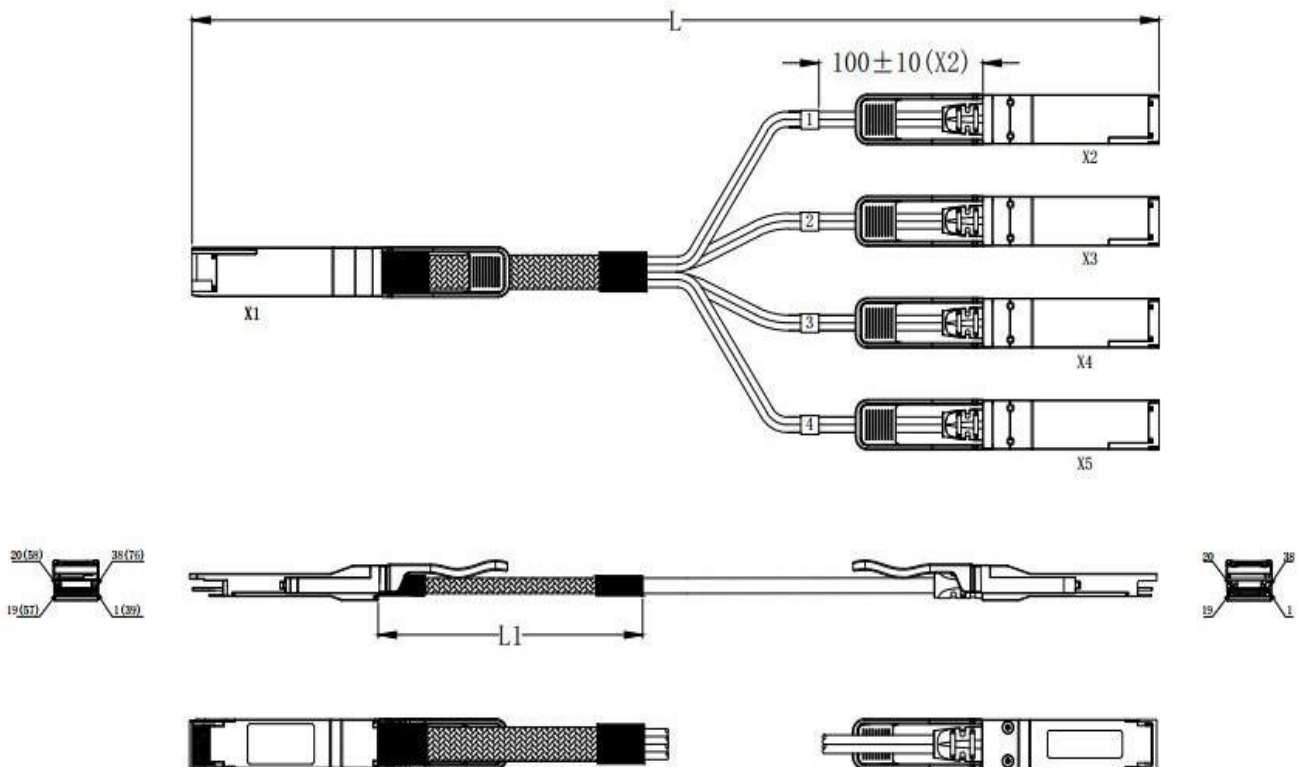

M.P/N	C.P/N	L(mm)	L1	AWG
QSFPDD-4*QSFP56-05301	TBD	500±15	100±10	30
QSFPDD-4*QSFP56-10301	TBD	1000±25	200±10	30
QSFPDD-4*QSFP56-15301	TBD	1500±30		30
QSFPDD-4*QSFP56-20281	TBD	2000±35		28
QSFPDD-4*QSFP56-25281	TBD	2500±35		27
QSFPDD-4*QSFP56-30281	TBD	3000±45		27

5 Wiring Diagram:

START			END	
GND	X1. 1	----	X2. 20	GND
TX2-	X1. 2	---->	X2. 21	RX2-
TX2+	X1. 3	---->	X2. 22	RX2+
GND	X1. 4	----	X3. 20	GND
TX4-	X1. 5	---->	X3. 21	RX2-
TX4+	X1. 6	---->	X3. 22	RX2+
GND	X1. 7	----	X3. 23	GND
MODSELL	X1. 8	----	X2. 27	MODPRSL
RESETL	X1. 9	----	X2. 28	INTL
VCCR1	X1. 10	----	X2. 29	VCCTX
SCL	X1. 11	----	X2. 30	VCC1
SDA	X1. 12	----	X2. 31	INITMODE
GND	X1. 13	----	X3. 35	GND
RX3+	X1. 14	<---	X3. 36	TX1+
RX3-	X1. 15	<---	X3. 37	TX1-
GND	X1. 16	----	X2. 35	GND
RX1+	X1. 17	<---	X2. 36	TX1+
RX1-	X1. 18	<---	X2. 37	TX1-
GND	X1. 19	----	X2. 38	GND
GND	X1. 20	----	X2. 1	GND
RX2-	X1. 21	<---	X2. 2	TX2-
RX2+	X1. 22	<---	X2. 3	TX2+
GND	X1. 23	----	X3. 1	GND
RX4-	X1. 24	<---	X3. 2	TX2-
RX4+	X1. 25	<---	X3. 3	TX2+
GND	X1. 26	----	X3. 4	GND
MODPRSL	X1. 27	----	X3. 8	MODSELL
INTL	X1. 28	----	X3. 9	RESETL
VCCTX	X1. 29	----	X3. 10	VCCR1
VCC1	X1. 30	----	X3. 11	SCL
INITMODE	X1. 31	----	X3. 12	SDA
GND	X1. 32	----	X3. 16	GND
TX3+	X1. 33	---->	X3. 17	RX1+
TX3-	X1. 34	---->	X3. 18	RX1-
GND	X1. 35	----	X2. 16	GND
TX1+	X1. 36	---->	X2. 17	RX1+
TX1-	X1. 37	---->	X2. 18	RX1-
GND	X1. 38	----	X2. 19	GND

START			END	
GND	X1. 39	----	X4. 20	GND
TX6-	X1. 40	---->	X4. 21	RX2-
TX6+	X1. 41	---->	X4. 22	RX2+
GND	X1. 42	----	X5. 20	GND
TX8-	X1. 43	---->	X5. 21	RX2-
TX8+	X1. 44	---->	X5. 22	RX2+
GND	X1. 45	----	X5. 23	GND
RESERVED	X1. 46	----	X4. 27	MODPRSL
VS1	X1. 47	----	X4. 28	INTL
VCCR1	X1. 48	----	X4. 29	VCCTX
VS2	X1. 49	----	X4. 30	VCC1
VS3	X1. 50	----	X4. 31	INITMODE
GND	X1. 51	----	X5. 35	GND
RX7+	X1. 52	<---	X5. 36	TX1+
RX7-	X1. 53	<---	X5. 37	TX1-
GND	X1. 54	----	X4. 35	GND
RX5+	X1. 55	<---	X4. 36	TX1+
RX5-	X1. 56	<---	X4. 37	TX1-
GND	X1. 57	----	X4. 38	GND
GND	X1. 58	----	X4. 1	GND
RX6-	X1. 59	<---	X4. 2	TX2-
RX6+	X1. 60	<---	X4. 3	TX2+
GND	X1. 61	----	X5. 1	GND
RX8-	X1. 62	<---	X5. 2	TX2-
RX8+	X1. 63	<---	X5. 3	TX2+
GND	X1. 64	----	X5. 4	GND
NC	X1. 65	----	X5. 8	MODSELL
RESERVED	X1. 66	----	X5. 9	RESETL
VCCTX1	X1. 67	----	X5. 10	VCCR1
VCC2	X1. 68	----	X5. 11	SCL
RESERVED	X1. 69	----	X5. 12	SDA
GND	X1. 70	----	X5. 16	GND
TX7+	X1. 71	---->	X5. 17	RX1+
TX7-	X1. 72	---->	X5. 18	RX1-
GND	X1. 73	----	X4. 16	GND
TX5+	X1. 74	---->	X4. 17	RX1+
TX5-	X1. 75	---->	X4. 18	RX1-
GND	X1. 76	----	X4. 19	GND

6 Electrical Performance:

6.1 Signal Integrity

(ITEM)		(REQUIREMENT)	(TEST CONDITION)				
(Differential Impedance)	Cable Impedance	105+5/-10Ω	Rise time of 25ps (20% - 80%).				
	Paddle Card Impedance	100±10Ω					
	Cable Termination Impedance	100±15Ω					
[Differential (Input/Output)Return loss S_{DD11}/S_{DD22}]		$\text{Return_loss}(f) \geq \left\{ \begin{array}{ll} 16.5-2\sqrt{f} & 0.05 \leq f < 4.1 \\ 10.66-14\log_{10}(f/5.5) & 4.1 \leq f \leq 19 \end{array} \right\}$ Where f is the frequency in GHz Return loss(f) is the return loss at frequency f	10MHz ≤ f ≤ 19GHz				
[Differential to common-mode (Input/Output)Return loss S_{CD11}/S_{CD22}]		$\text{Return_loss}(f) \geq \left\{ \begin{array}{ll} 22-(20/25.78)f & 0.01 \leq f < 12.89 \\ 15-(6/25.78)f & 12.89 \leq f \leq 19 \end{array} \right\}$ Where f is the frequency in GHz Return_loss(f) is the Differential to common-mode return loss at frequency f	10MHz ≤ f ≤ 19GHz				
[Common-mode to Common-mode (Input/Output)Return loss S_{CC11}/S_{CC22}]		$\text{Return_loss}(f) \geq 2\text{dB} \quad 0.2 \leq f \leq 19$ Where f is the frequency in GHz Return_loss(f) is the common-mode to common-mode return loss at frequency f	10MHz ≤ f ≤ 19GHz				
[Differential Insertion Loss (S_{DD21} Max.)]		(Differential Insertion Loss Max. For TPa to TPb Excluding Test fixture)					10MHz ≤ f ≤ 19GHz
F AWG	1.25GHz	2.5GHz	5.0GHz	7.0GHz	10Ghz	12.89Ghz	
30(1m) Max.	4.5dB	5.4dB	6.3dB	7.5dB	8.5dB	10.5dB	
30/28(3m)Max.	7.5dB	9.5dB	12.2dB	14.8dB	18.0dB	21.5dB	

	26(3m) Max.	5.7dB	7.2dB	9.9 dB	11.9dB	14.1dB	16.5dB	
	26/25(5m)Max.	7.8dB	10.0dB	13.5dB	16.0dB	19.0dB	22.0dB	
Differential to common-mode Conversion Loss-Differential Insertion Loss(S _{CD21} -S _{DD21})	$\text{Conversion_loss}(f) - \text{IL}(f) \geq \begin{cases} 10 & 0.01 \leq f < 12.89 \\ 27 - (29/22)f & 12.89 \leq f < 19 \end{cases}$ <p>Where f is the frequency in GHz $\text{Conversion_loss}(f)$ is the cable assembly differential to common-mode conversion loss $\text{IL}(f)$ is the cable assembly insertion loss</p>							10MHz ≤ f ≤ 19GHz
[MDNEXT(multiple disturber near-end crosstalk)]	≥26dB @12.89GHz							10MHz ≤ f ≤ 19GHz

6.2 (Other Electrical Performance)

(ITEM)	(REQUIREMENT)	(TEST CONDITON)
[Low Level Contact Resistance]	70milliohms Max. From initial.	EIA-364-23:Apply a maximum voltage of 20mV And a current of 100 mA.
Insulation Resistance	10Mohm(Min.)	EIA364-21:AC 300V 1minute
[Dielectric Withstanding Voltage]	NO disruptive discharge.	EIA-364-20:Apply a voltage of 300 VDC for 1minute between adjacent terminals And between adjacent terminals and ground.

7 (Environment Performance)

(ITEM)	(REQUIREMENT)	(TEST CONDITON)
[Operating Temp. Range]	-20°C to +75°C	Cable operating temperature range.
[Storage Temp. Range]	-40°C to +80°C	Cable storage temperature range in packed condition.

(in packed condition)]		
[Thermal Cycling Non-Powered]	No evidence of physical damage	EIA-364-32D, Method A, -25 to 90C, 100 cycles, 15 min. dwells
[Salt Spraying]	48 hours salt spraying after shell corrosive area less than 5%.	EIA-364-26
Mixed Flowing Gas	Pass electrical tests per 3.1 after stressing. (For connector only)	EIA-364-35 Class II, 14 days.
Temp. Life	No evidence of physical damage	EIA-364-17C w/ RH, Damp heat 90°C at 85% RH for 500 hours then return to ambient
Cable Cold Bend	4H, No evidence of physical damage	Condition: -20°C±2°C, mandrel diameter is 6 times the cable diameter.

8 (Mechanical and Physical Characteristics)

(ITEM)	(REQUIREMENT)	(TEST CONDITON)
Vibration	Pass electrical tests per 3.1 after stressing.	Clamp & vibrate per EIA-364-28E, TC-VII, test condition letter – D, 15 minutes in X, Y & Z axis.
Cable Flex	No evidence of physical damage	Flex cable 180° for 20 cycles (±90° from nominal position) at 12 cycles per minute with a 1.0kg load applied to the cable jacket. Flex in the boot area 90° in each direction from vertical. Per EIA-364-41C
Cable Plug Retention in Cage	90N Min. No evidence of physical damage	Force to be applied axially with no damage to cage. Per SFF 8661 Rev 2.1 Pull on cable jacket approximately 1 ft behind cable plug. No functional damage to cable plug below 90N. Per SFF-8432 Rev 5.0
Cable Retention in Plug	90N Min. No evidence of physical damage	Cable plug is fixtured with the bulk cable hanging vertically. A 90N axial load is applied (gradually) to the cable jacket and held for 1 minute. Per EIA-364-38B
Mechanical Shock	Pass electrical tests Per 3.1 after stressing.	Clamp and shock per EIA-364-27B, TC-G, 3 times in 6 directions, 100g, 6ms.
Cable Plug Insertion	40N Max.(QSFP56) 90N Max.(QSFP DD)	Per SFF8661 Rev 2.1 Per QSFP-DD Hardware Rev 5.0



Cable plug Extraction	30N Max. (QSFP56) 50N Max.(QSFP DD)	Place axial load on de-latch to de-latch plug.Per SFF8661 Rev 2.1 Measure without the aid of any cage kick-out springs. Place axial load on de-latch to de-latch plug. Per SFF-8432 Rev 5.0
Durability	50 cycles, No evidence of physical damage	EIA-364-09, perform plug & unplug cycles: Plug and receptacle mate rate: 250times/hour. 50times for QSFP28/SFP28 module (CONNECTOR TO PCB)