



XGS-PON ONU SFP+ Transceiver

XGS-PON-ONU-20

FEATURES

- Single fiber bi-directional data links asymmetric TX 9.953Gbps/RX9.953Gbps application
- 0 to 70°C operating case temperature
- Single 3.3V power supply
- SFP+ package with SC/UPC Receptacle connector
- Hot-pluggable capability
- High power 1270nm DML DFB LD and high sensitivity 1577nm APD
- Support 20km transmission distance with SMF
- CML compatible data input/output interface
- Low power dissipation
- Low EMI and excellent ESD protection
- Digital diagnostic monitor interface
- RoHS-6 compliance

APPLICATIONS

- 10-Gigabit-capable passive optical networks

STANDARDS

- Complies with SFP+ MSA (SFF-8431)
- Complies with ITU-T G.9807
- Complies with SFF-8472
- Complies with FCC 47 CFR Part 15, Class B
- Complies with FDA 21 CFR 1040.10 and 1040.11, Class I
- Complies with FDA 21 CFR 1040.10 and 1040.11 except for deviations pursuant to Laser Notice No. 50, dated June 24, 2007

ABSOLUTE MAXIMUM RATING

Parameter	Symbol	Min.	Max.	Unit	Notes
Storage Ambient Temperature	T_{STG}	-40	85	°C	
Operating Case Temperature	T_c	0	70	°C	
Operating Humidity	OH	5	95	%	
Power Supply Voltage	V_{CC}	0	3.6	V	

RECOMMENDED OPERATING CONDITION

Parameter	Symbol	Min.	Typ.	Max.	Unit	Notes
Operating Case Temperature	T_c	0		70	°C	
Power Supply Voltage	V_{CC}	3.15	3.3	3.45	V	
Power Supply Current	I_{CC}			600	mA	
Nominal upstream line rate			9.953		Gbps	
Nominal downstream line rate			9.953		Gbps	
Max Input power				3	dBm	

TRANSMITTER OPTICAL CHARACTERISTICS

Parameter	Symbol	Min.	Typ.	Max.	Unit	Notes
Average Launch Optical Power	P_{OUT}	4	-	9	dBm	EOL, over temperature, Launched into 9/125 μ m single mode fiber
		5	-	9	dBm	BOL, Room temperature, Launched into 9/125 μ m single mode fiber
Extinction Ratio	ER	6	-	-	dB	
Centre Wavelength	λ	1260	1270	1280	nm	
Spectral Width (-20dB)	$\Delta\lambda$	-	-	1	nm	
Side Mode Suppression Mode	SMSR	30			dB	
Burst on time	T-on			50	ns	
Burst off time	T-off			50	ns	
Tx-SD Assert	SD-on			350	ns	
Tx-SD De-Assert	SD-off			350	ns	
Transmitter and dispersion penalty	TDP			3	dB	Transmit on 20km SMF
Transmitter tolerance to reflected optical power		-15			dB	
Eye Diagram	Compliant With ITU-T G.987.2					PRBS 2 ³¹ -1 test pattern @9.953Gbit/s

TRANSMITTER ELECTRICAL CHARACTERISTICS						
Parameter	Sym	Min.	Typ.	Max.	Unit	Notes
Input Differential Impedance	ZIN	90	100	110	Ω	
Data Input Swing Differential	VIN	200	-	1600	mV	
Burst Disable		2.0		V _{cc}	V	
Burst Enable		0		0.8	V	
Tx-Fault Voltage - Low		0		0.4	V	
Tx-Fault Voltage - High		2.4		V _{cc}	V	

RECEIVER CHARACTERISTICS						
Parameter	Sym	Min.	Typ.	Max.	Unit	Notes
Optical Center Wavelength	λ_c	1575	1577	1580	nm	
Receiver Sensitivity (EOL, over temperature)	SEN			-28	dBm	Measured with PRBS 2 ³¹ -1 test pattern @9.953Gbit/s, BER $\leq 1 \times 10^{-3}$
Receiver Sensitivity (BOL Room temperature)	SEN			-29	dBm	
Receiver Overload		-8			dBm	Measured with PRBS 2 ³¹ -1 test pattern @9.953Gbit/s, BER $\leq 1 \times 10^{-3}$
Receiver reflectance				-12	dB	
Optical Return Loss tolerance	-15				dB	
SD Assert	SDA			-29	dBm	
SD De-Assert	SDD	-45			dBm	
SD Hysteresis		0.5		5	dB	
Data Output Swing Differential	V _{OUT}	300	-	850	mV	
SD	High	2.4	-	V _{cc}	V	
	Low	0	-	0.4	V	

PIN DESCRIPTION			
PIN	Name	Description	Notes
1	VeeT	Module Transmitter Ground	
2	Tx_Fault	Module Transmitter Fault	Low : normal; High: abnormal
3	Tx_Burst	Transmitter Burst Enable	TTL Input, Low : transmitter on
4	SDA	Module Definition 2	2 wire serial ID interface, SDA
5	SCL	Module Definition 1	2 wire serial ID interface, SCL
6	MOD_ABS	Module Absent	Connected to VeeT or VeeR in the module
7	TX_SD	Tx Transmitter State Indication	TX_Indication Assert When Transmitter ON
8	Rx_SD	Receiver Signal Indication	High: signal detected; Low : loss of signal
9	NC	Not Connect	NC
10	VeeR	Module Receiver Ground	
11	VeeR	Module Receiver Ground	
12	RD-	Inverted Received Data Out	AC-coupled,
13	RD+	Non-inverted Received Data Out	AC-coupled,
14	VeeR	Module Receiver Ground	
15	VCCR	Module Receiver 3.3 V Supply	
16	VCCT	Module Transmitter 3.3 V Supply	
17	VeeT	Module Transmitter Ground	
18	TD+	Non-Inverted Transmit Data in	AC-coupled
19	TD-	Inverted Transmit Data in	AC-coupled
20	VeeT	Module Transmitter Ground	

PIN OUT DRAWING

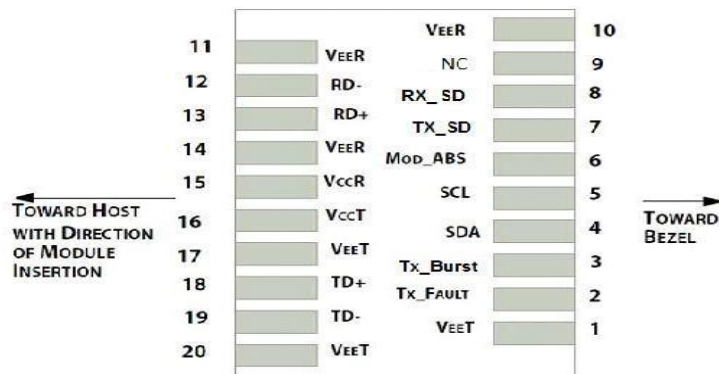

Figure 1 Pin out Drawing

TYPICAL INTERFACE CIRCUIT

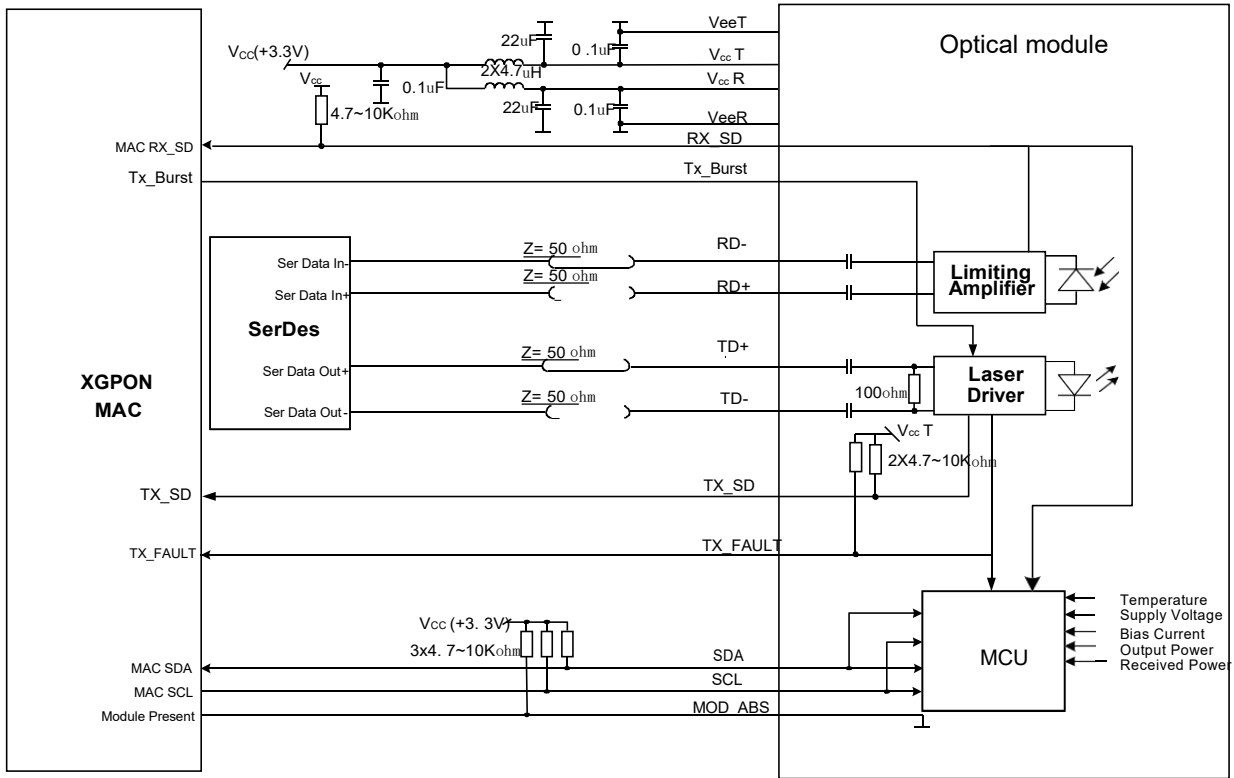

Figure 2 Typical Interface Circuit

PACKAGE OUTLINE

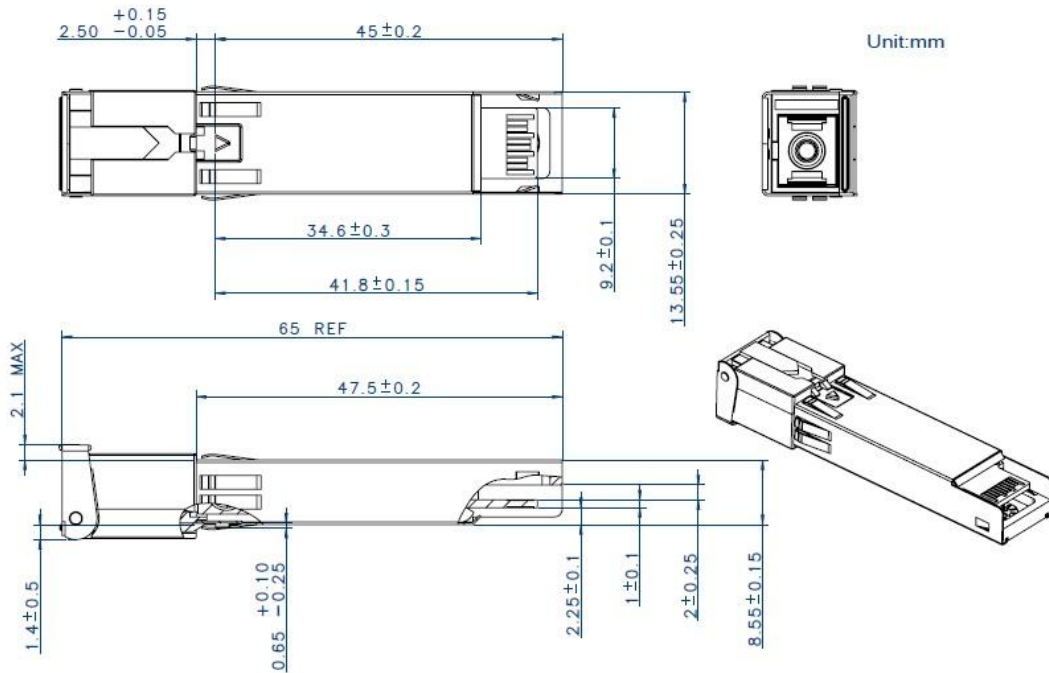

Figure 3 Package Outline

EEPROM INFORMATION

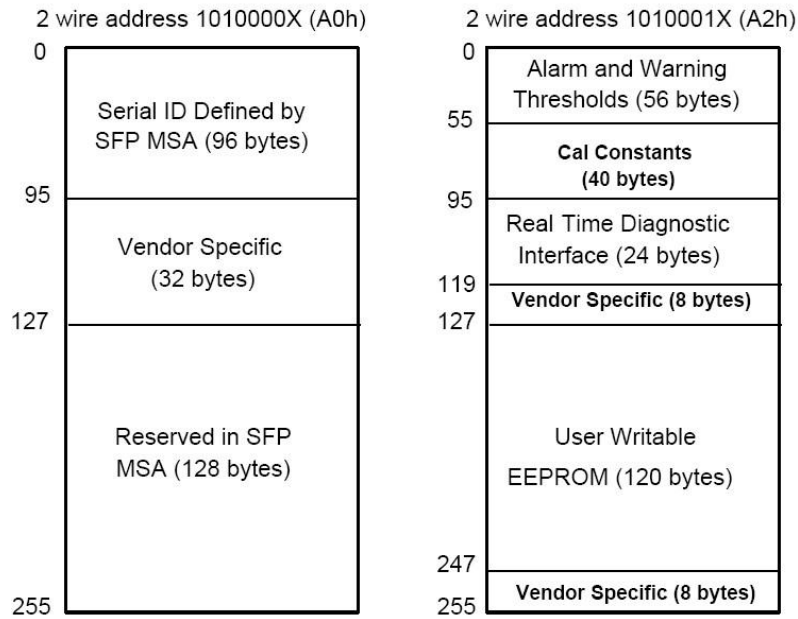

Figure 4 EEPROM Memory Map Specific Data Field Descriptions

DIGITAL DIAGNOSTIC MONITORING INTERFACE

Parameter	Range	Accuracy	Calibration	Notes
Temperature	0 to 70°C	±3°C	Internal	1LSB = 1/256°C
Voltage	3 to 3.6V	±3%	Internal	1LSB = 0.1mV
Bias Current	0 to 131mA	±10%	Internal	1LSB = 4uA
TX Power	4 to 9dBm	±2dB	Internal	1LSB = 0.2uW
RX Power monitor	-29 to -8dBm	±3dB	Internal	1LSB = 0.1uW

ORDERING INFORMATION

PN	Temperature Rating	Unit
XGS-PON-ONU-20	0 ~ 70	°C

WARNINGS

- Handling Precautions: This device is susceptible to damage as a result of electrostatic discharge (ESD). A static free environment is highly recommended. Follow guidelines according to proper ESD procedures.
- Laser Safety: Radiation emitted by laser devices can be dangerous to human eyes. Avoid eye exposure to direct or indirect radiation.