



EPON-OLT-PX20++

GEPON OLT PX20++ Enhanced Optical Module

Product Features

- Compatible IEEE 802.3ah 1000BASE-PX20++ Enhanced GEPON application
- Applied to EPON OLT for a Single Fiber Bi-directional EPON System
- SFP, Single SC connector, Digital Diagnostic Interface Compliant with SFF-8472
- Burst Digital Receiving Signal Strength Indication (RSSI)
- Single 3.3V power supply
- Operation case temperature -10~70°C for commercial
- RoHS-6 compliance

Absolute Maximum Ratings

Parameter	Unit	Min.	Typical	Max.
Power Supply	V	0		4.2
Storage Ambient Temperature	°C	-40		85
Operating Case Temperature	°C	-40		85
Operating Relative Humidity	%	5		95
Receiver Damaged Threshold	dBm	0		

Operating Condition

Parameter	Unit	Min.	Typical	Max.
Power Supply	V	3.1	3.3	3.5
Operating Case Temp for C-temp	°C	-10		70
Operating Relative Humidity	%	5		95
Data Rate(TX/RX)	Gbit/s		1.25	

Optical Characteristics

Parameter	Unit	Min.	Typ.	Max.
TX Central Wavelength	nm	1480		1500
Spectral Width (-20dB)	nm			1
SMSR	dB	30		
Mean Launched Power (BOL)	dBm	7	7.5	10
Mean Launched Power (TX Off)	dBm			-39
Extinction Ratio(Note 1)	dB	9		
TX Total Jitter	UI			0.43
Rise/Fall Time (20%-80%)	ps			260
RIN ₁₅ OMA	dB/Hz			-115
Optical Return Loss Tolerance	dB	-12		
Transmitter and dispersion Penalty(20km G.652)	dB			2.3
TX Optical Eye Mask	Compliant With IEEE Std 802.3ah™-2004			
Receive Wavelength	nm	1260		1360
Sensitivity (Note 2)	dBm			-33
Overload	dBm	-6		
Dynamic Rang	dB	25		
Receiver Threshold Settling Time	ns			250
RX Dynamic Range(Note 3)	dBm	-30		-6
LOS-Deassert	dBm			-34
LOS-Assert	dBm	-45		
SD Hysteresis	dB	0.5		6
Receiver Reflectance	dB			-12

Note:

1. Measured with PRBS 2⁷-1 test pattern @1.25Gbps, Low Pass Filter is on.
2. Measured with a PRBS 2⁷-1 test pattern @1.25Gbps and ER=10dB, BER <10⁻¹²
3. RX Dynamic Range Definition

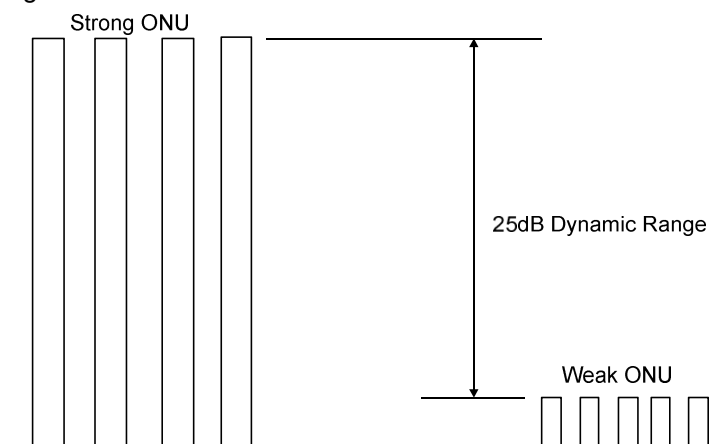

Electrical Characteristics

Parameter	Unit	Min.	Typical	Max.
Power Supply Current	mA			300
Data Input Differential Swing	mV	200		1600
Data Differential Impedance	Ω	90	100	110
TTL Input -Low	V	0		0.8
TTL Input -High	V	2.0		V _{cc}
TTL Output -Low	V	0		0.4
TTL Output -High	V	2.4		V _{cc}
Data Output Differential Swing	mV	400		1600
Los Assert Time	ns			500
Los Deassert Time	ns			500

RSSI Trigger Time Sequence

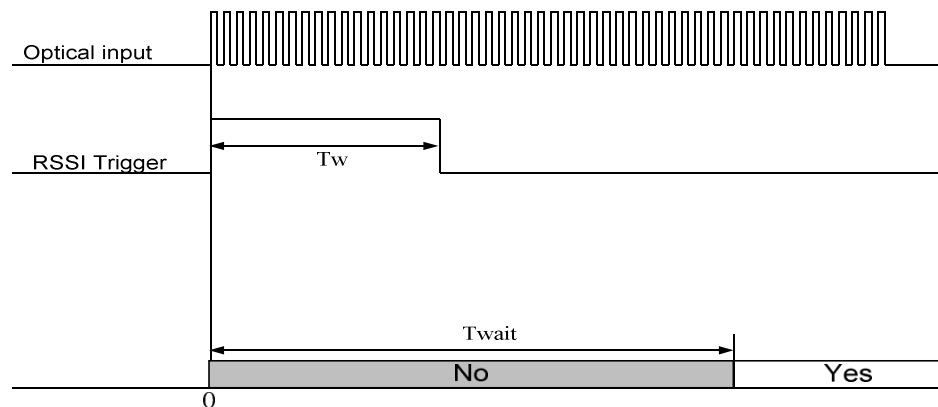

Item	Symbol	Min	Max	unit
Trigger width	T_w	1	1.25	us
I ² C Waiting Time	T_{wait}		500	us

Pin Definition

Pin No.	Name	Level/Logic	Function	Description
1	GNDT	NA	Ground	Transmitter Ground
2	TX_Fault	LVTTTL	TX Fault	TX Fault Alarm, TX Fault State: High; TX Normal State: Low
3	TX_Dis	LVTTTL	Transmitter Enable/Disable	Active High
4	MOD-DEF2	LVTTTL	SDA	I2C clock
5	MOD-DEF1	LVTTTL	SCL	I2C data
6	MOD-DEF0	MOD-DEF0		Module Definition 0, Grounding in SFP
7	RSSI_Trig	LVTTTL	RSSI Trigger	Active High for Sampling
8	LOS	LVTTTL	Receiver Signal Detection	Loss of Signal. Asserted when light is off
9	GNDR	NA	Ground	Receiver Ground
10	GNDR	NA	Ground	Receiver Ground
11	GNDR	NA	Ground	Receiver Ground
12	RD-	LVPECL	Rx Data-	RX data NOT output, DC coupled output
13	RD+	LVPECL	Rx Data+	RX data output, DC coupled output
14	GNDR	GNDR	Ground	Receiver Ground
15	V _{cc} R	NA	Receiver Power Supply	Rx Power
16	V _{cc} T	NA	Transmitter Power Supply	Tx Power
17	GNDT	GNDT	Ground	Transmitter Ground
18	TD+	LVPECL	Tx Data+	TX data input, internally AC coupled with 100ohm terminated
19	TD-	LVPECL	Tx Data-	TX data NOT input, internally AC coupled with 100ohm terminated
20	GNDT	NA	Ground	Transmitter Ground

Recommended Interface Circuit

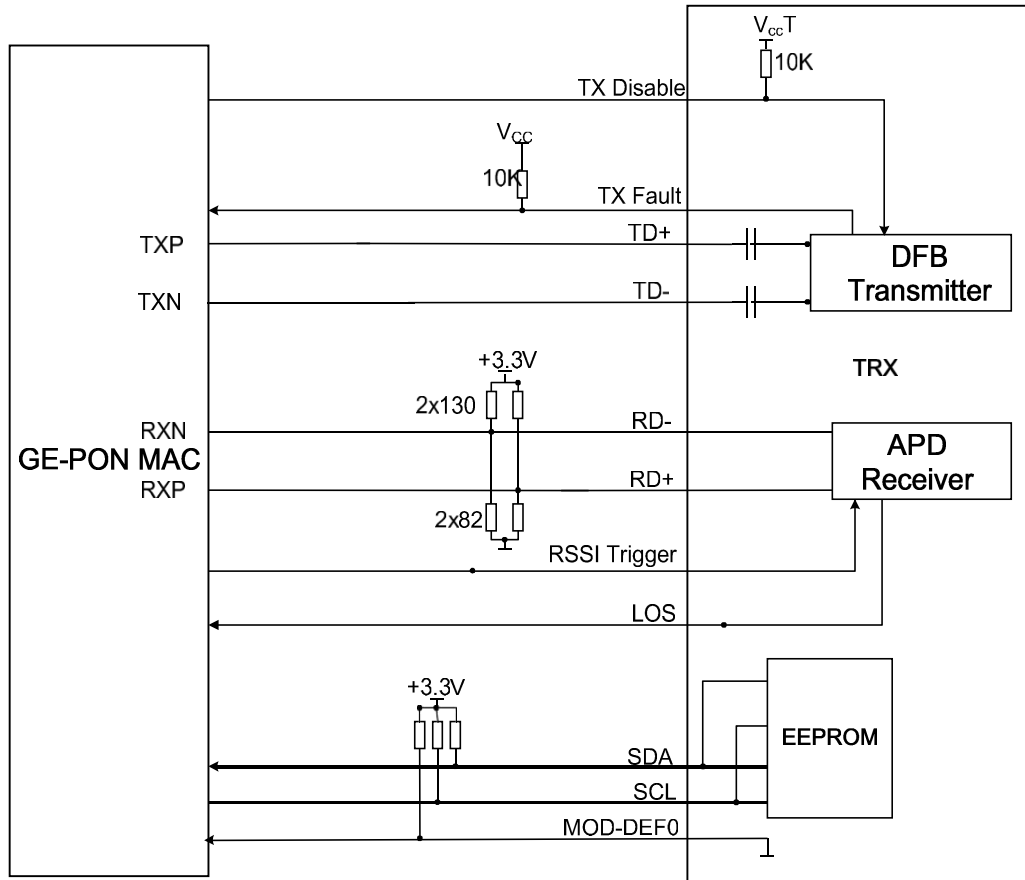

Mechanical Diagram

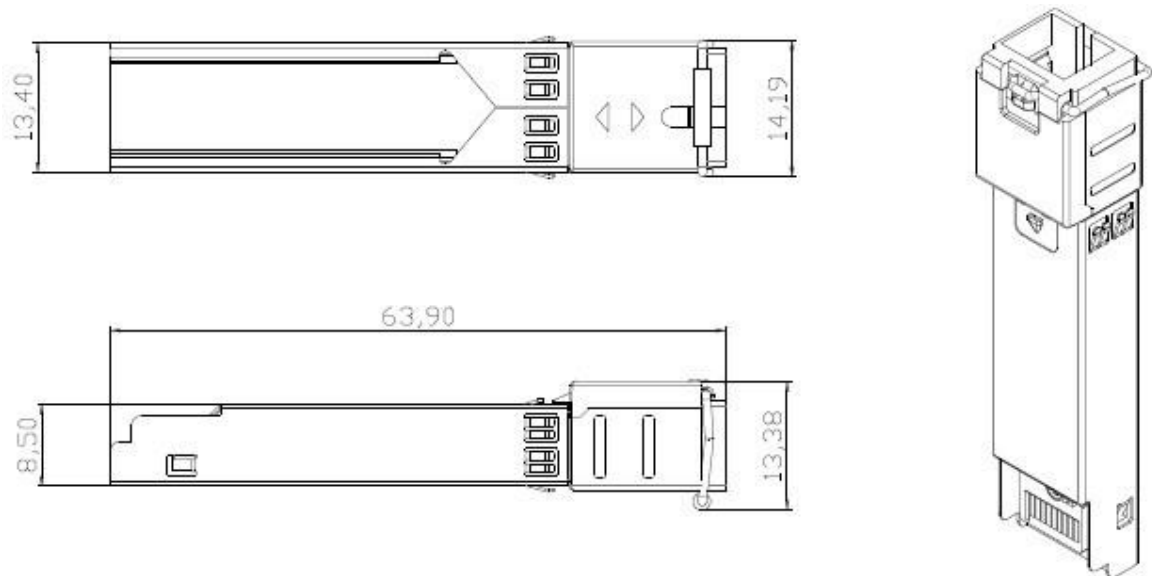



EEPROM Information

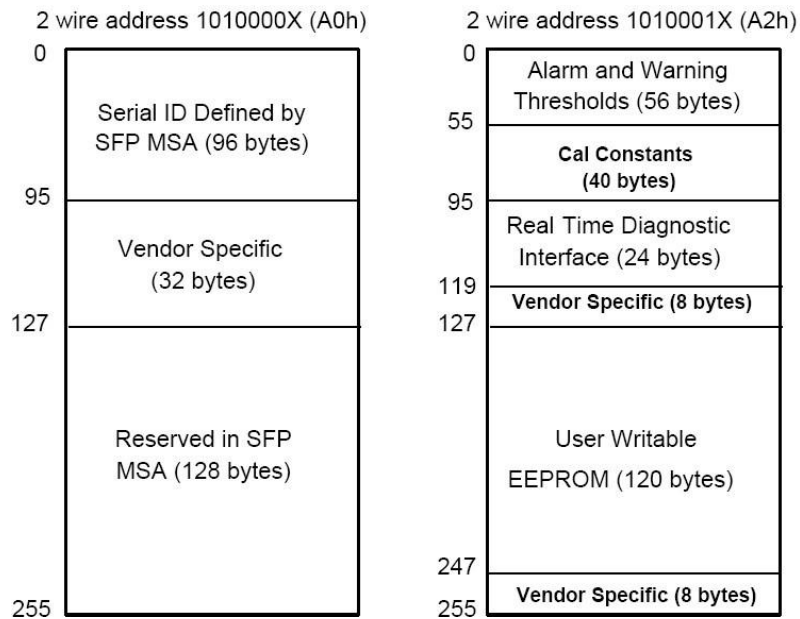

Ordering Information

Ordering P/Ns	Description
EPON-OLT-PX20++	EPON OLT PX20++ Enhanced Diplexer, 20km, Tx 1490nm 1.25G, Rx 1310nm 1.25G, SFP form-factor, SC/UPC receptacle connector, Commercial temperature, V3 version mechanical housing.

Version	Date	Description
V0	Mar-1-2017	New release
V1	Oct-19-2020	Update the housing diagram
V2	Apr-19-2021	Update the fiber distance from 30km to 20km