

GPON-OLT-B+I

GPON OLT Class B+ SFP Transceiver

FEATURES

- Single fiber bi-directional data links asymmetric TX 2488Mbps/RX1244Mbps application
- 1490nm continuous-mode DFB laser transmitter and 1310nm burst-mode APD-TIA receiver
- Small Form Factor Pluggable package with SC/UPC Connector
- Reset burst-mode receiver design support more than 15dB dynamic range
- -40 to 85°C operating case temperature
- Single 3.3V power supply
- Digital diagnostic monitoring interface
- Digital burst RSSI function to monitor the input optical power level
- LVPECL compatible data input/output interface
- LVTTTL transmitter disable control
- LVTTTL transmitter laser fault alarm
- LVTTTL receiver Signal Detect (SD) indication
- Low EMI and excellent ESD protection
- Class I laser safety standard IEC-60825 compliant
- RoHS-6 compliance

APPLICATIONS

- Gigabit-capable Passive Optical Networks (GPON) 20Km 13~28dB attenuation range.

STANDARDS

- Complies with SFP Multi-Source Agreement (MSA) SFF-8074i
- Complies with ITU-T G.984.2 Amendment 1
- Complies with SFF-8472 Rev 9.5
- Complies with FCC 47 CFR Part 15, Class B
- Complies with FDA 21 CFR 1040.10 and 1040.11

Parameter	Symbol	Min.	Max.	Unit	Notes
Storage Ambient Temperature	T _{STG}	-40	85	°C	
Operating Case Temperature	T _c	-40	85	°C	
Operating Humidity	OH	5	95	%	
Power Supply Voltage	V _{CC}	0	3.6	V	
Receiver Damaged Threshold		+4		dBm	

RECOMMENDED OPERATING CONDITION

Parameter	Symbol	Min.	Typ.	Max.	Unit	Notes
Power Supply Voltage	V _{CC}	3.13	3.3	3.47	V	
Operating Case Temperature	T _c	-40		85	°C	
Operating Humidity Range	OH	5		95	%	
Data Rate			Tx 2488.32 Rx 1244.16		Mbit/s	

TRANSMITTER OPTICAL CHARACTERISTICS

Parameter	Symbol	Min.	Typ.	Max.	Unit	Notes
Optical Center Wavelength	λ_c	1480		1500	nm	
Optical Spectrum Width (-20dB)	$\Delta\lambda$			1	nm	
Side Mode Suppression Ratio	SMSR	30			dB	
Average Launch Optical Power	AOP	+2.5		+5	dBm	BOL, Room Temperature
		+1.5		+5	dBm	EOL, -40~85°C
Power-OFF Transmitter Optical Power				-39	dBm	Launched into SMF
Extinction Ratio	ER	8.2			dB	PRBS 2 ²³ -1+72CID @2.488Gbit/s
Tolerance to Transmitter Incident Light		-15			dB	
Transmitter Reflectance				-10	dB	
Transmitter and Dispersion Penalty	TDP			1	dB	Transmit on 20km SMF
Optical Waveform Diagram		ITU-T G.984.2				Figure 1

TRANSMITTER EYE MASK DEFINITIONS AND TEST PROCEDURE

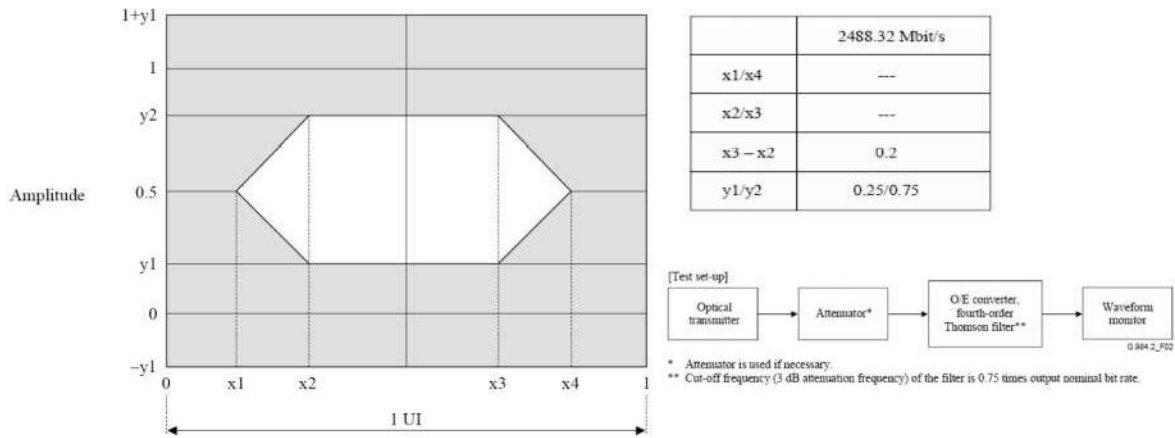

Figure 1 Transmitter Eye Mask Definitions and Test Procedure

TRANSMITTER ELECTRICAL CHARACTERISTICS

Parameter	Symbol	Min.	Typ.	Max.	Unit	Notes
Data Input Differential Swing		200		1600	mV	LVPECL input, AC coupled
Input Differential Impedance		90	100	110	Ω	
Power Supply Current				220	mA	Load free
Transmitter Disable Voltage - Low		0		0.8	V	
Transmitter Disable Voltage - High		2.0		V _{CC}	V	
Transmitter Fault Alarm Voltage - Low		0		0.4	V	
Transmitter Fault Alarm Voltage - High		2.4		V _{CC}	V	

RECEIVER OPTICAL CHARACTERISTICS

Parameter	Symbol	Min.	Typ.	Max.	Unit	Notes
Operating Wavelength		1260		1360	nm	
Sensitivity	SEN			-28	dBm	PRBS 2 ²³ -1+72CID@1244M bps BER $\leq 1 \times 10^{-10}$
Saturation Optical Power	SAT	-8			dBm	
Dynamic Range		15			dB	Figure 2
Signal Detect Assert Level				-30	dBm	
Signal Detect De-Assert Level		-45			dBm	
Signal Detect Hysteresis		0.5		6	dB	
Receiver Reflectance				-12	dB	

BURST MODE RECEIVER DYNAMIC RANGE IN GPON SYSTEM

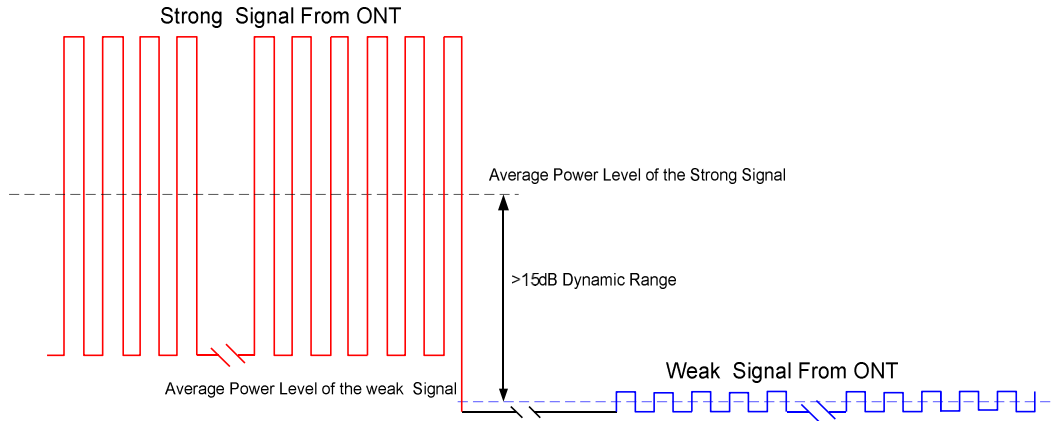

Figure 2 Burst Mode Receiver Dynamic Range in GPON System

RECEIVER ELECTRICAL CHARACTERISTICS

Parameter	Symbol	Min.	Typ.	Max	Unit	Notes
Power Supply Current				350	mA	Load free
Data Output Voltage – Low (-Vcc)		-1.81		-1.62	V	
Data Output Voltage – High (-Vcc)		-1.02		-0.88	V	
Data Output Differential Swing		400		1600	mV	LVPECL output, DC coupled
Reset width	TRESET	16			bits	
Reset-Low		0		0.4	V	
Reset-High		2.4		Vcc	V	
Receiver Amplitude Recovery Time	TRECOVERY			32	bits	Refer to the Reset signal falling edge
Signal Detect Assert Time				50	ns	
Signal Detect De-assert Time				12.8	ns	Refer to the Reset signal rising edge
Signal Detect Voltage-Low		0		0.4	V	
Signal Detect Voltage-High		2.4		Vcc	V	
RSSI Trigger-Low		0		0.8	V	
RSSI Trigger-High		2.0		Vcc	V	
RSSI Trigger width	T _w	350	375	400	ns	
RSSI Trigger Delay	T _D		500		ns	Refer to first bit of the preamble
Optical Signal During Time	TONT EN_DUR EN_DUR		2600		ns	TONT EN_DUR ≥ T _D + T _w For RSSI Measurement
I2C Access Prohibited Time		100		500	μs	

RX Power Monitor Range	-30	-8	dBm	Note 1
------------------------	-----	----	-----	--------

Note 1: RSSI result is provided by access to EEPROM A2H 104~105Byte the unit is 0.1uW. Please refer to the SFF-8472 V9.5 for the detail information.

TIMING PARAMETER DEFINITIONS IN BURST MODE SEQUENCE

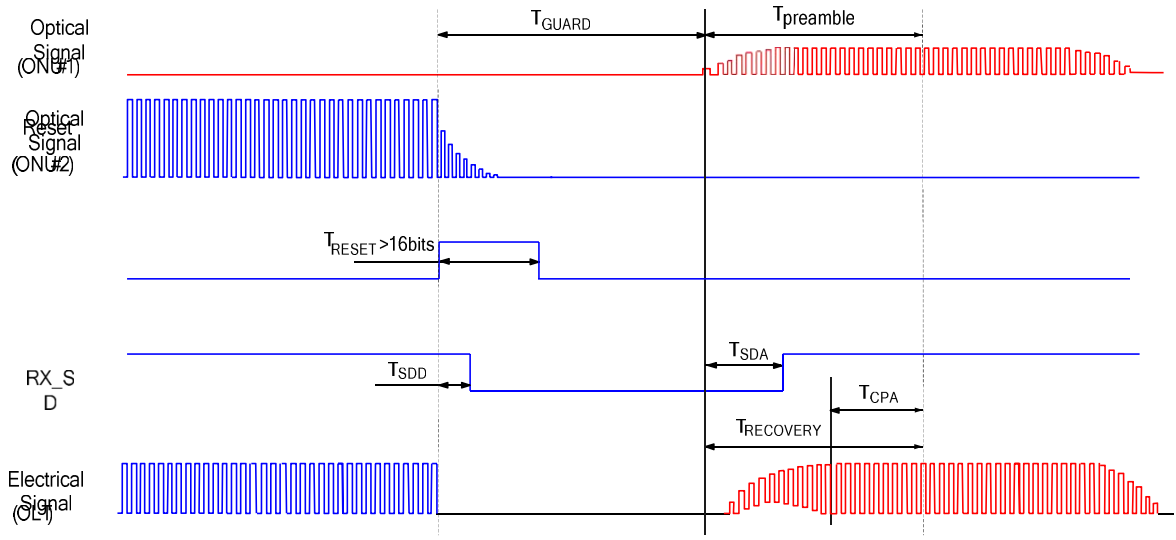

Figure 3 Burst Receiver Timing Sequence

RSSI TIMING SEQUENCE

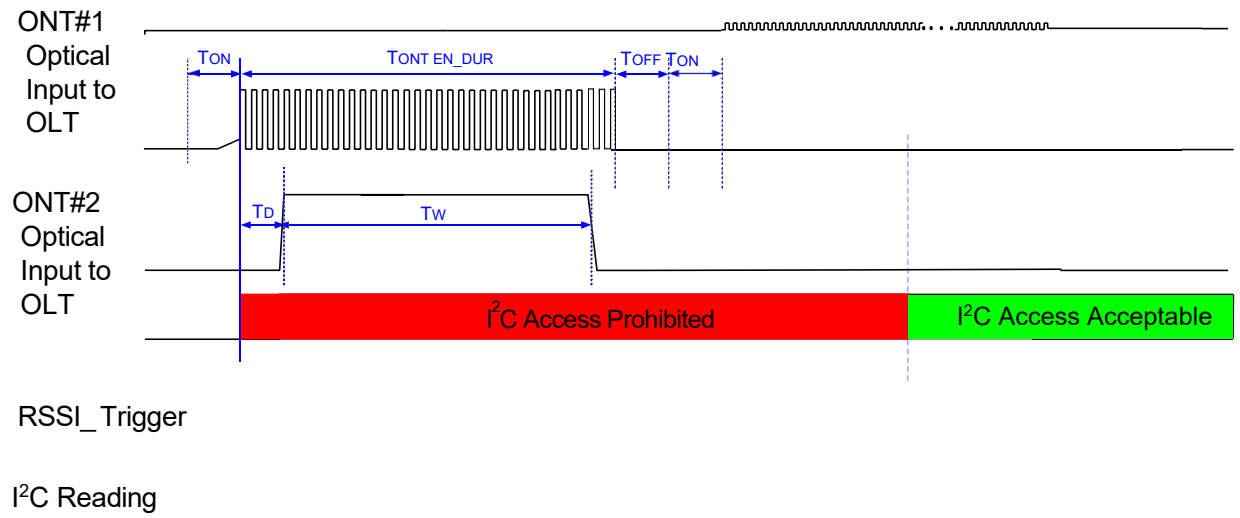

Figure 4 RSSI TIMING SEQUENCE

PIN DESCRIPTION

PIN	Name	Description	Notes
1	V _{EE} T	Transmitter Ground	
2	TX Fault	Transmitter Fault Indication	High: abnormal; Low: normal
3	TX Disable	Transmitter Disable	High: transmitter disable; Low: transmitter enable
4	MOD-DEF2	Module Definition 2	The data line of two wire serial interface
5	MOD-DEF1	Module Definition 1	The clock line of two wire serial interface
6	MOD-DEF0	Module Definition 0	Connected to Ground in the transceiver
7	Reset	Receiver Reset	High: reset the receiver
8	SD	Signal Detect	High: signal detected; Low: loss of signal;
9	RSSI Trigger	RSSI Trigger for Transceiver A/D	High: enable RSSI A/D conversion
10	V _{EE} R	Receiver Ground	
11	V _{EE} R	Receiver Ground	
12	RD-	Inv. Receiver Data Out	LVPECL logic output, DC coupled
13	RD+	Receiver Data Out	LVPECL logic output, DC coupled
14	V _{EE} R	Received Ground	
15	V _{CC} R	Receiver Power	
16	V _{CC} T	Transmitter Power	
17	V _{EE} T	Transmitter Ground	
18	TD+	Transmit Data In	LVPECL logic input, AC coupled
19	TD-	Inv. Transmit Data In	LVPECL logic input, AC coupled
20	V _{EE} T	Transmitter Ground	

SFP RECOMMENDED HOST BOARD POWER SUPPLY FILTERING NETWORK

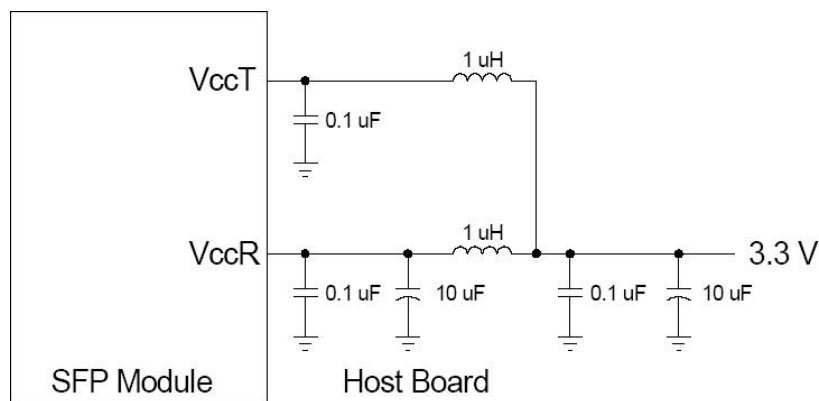

Figure 5 SFP Recommended Host Board Power Supply Filtering Network

SFP PIN (GOLDEN FINGER) DRAWING

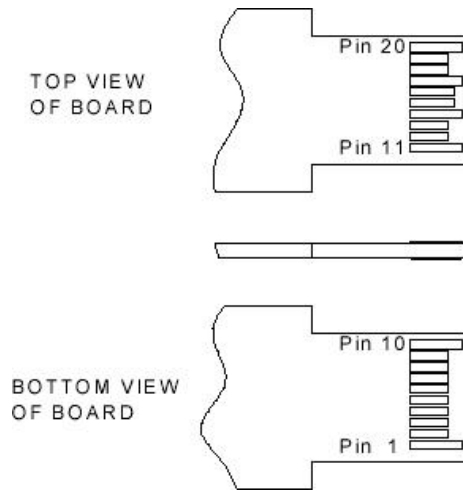

Figure 6 SFP Pin (Golden Finger) Drawing

TYPICAL INTERFACE CIRCUIT

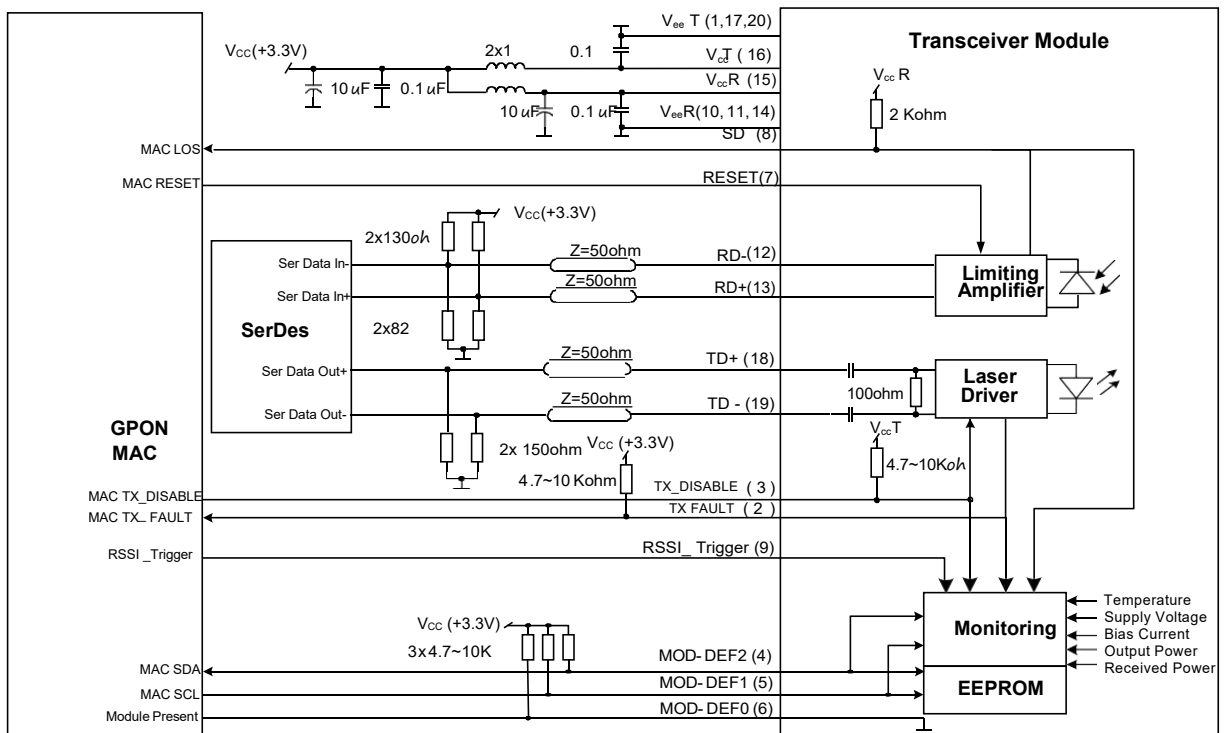

Figure 7 Typical Interface Circuit

Unit:mm

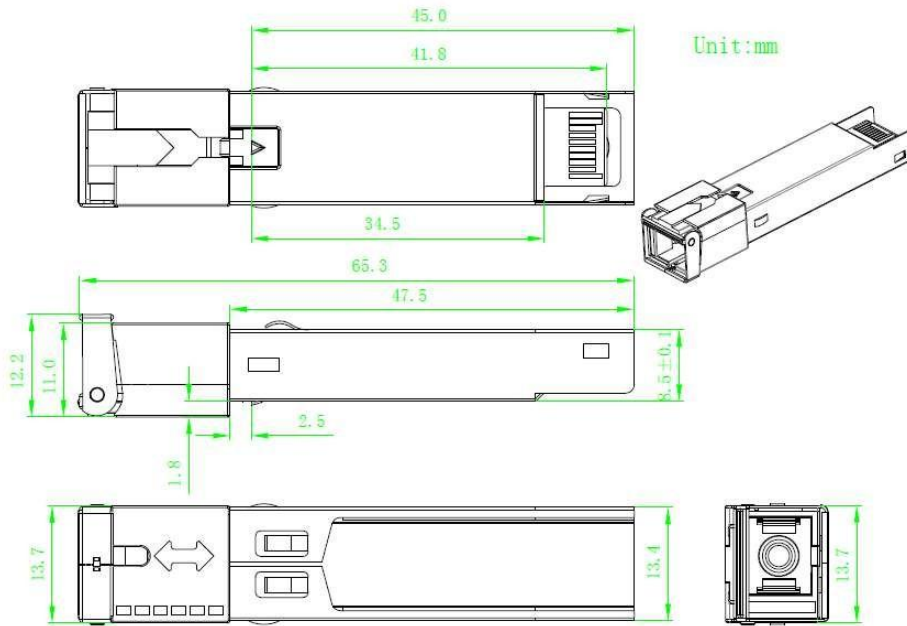

Figure 8 Package Outline

EEPROM INFORMATION

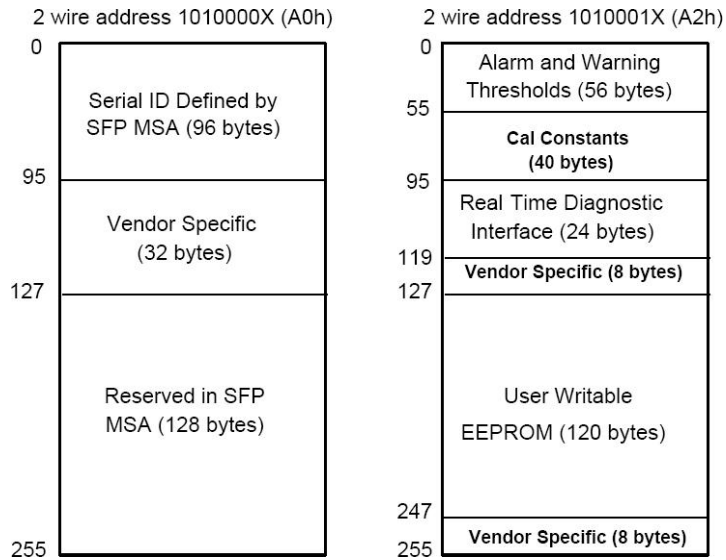

Figure 9 EEPROM Memory Map Specific Data Field Descriptions



DIGITAL DIAGNOSTIC MONITORING INTERFACE

Parameter	Range	Accuracy	Calibration	Note
Temperature	-40 to 85°C	±3°C	Internal	1LSB = 1/256°C
Voltage	3.0 to 3.7V	±3%	Internal	1LSB = 0.1mV
Bias Current	0 to 100mA	±10%	Internal	1LSB = 2uA
TX Power	1.5 to 5dBm	±2dB	Internal	1LSB = 0.1uW
RX Power Monitor	-30 to -8dBm	±3dB	External	1LSB = 0.1uW

Note : The digital diagnostic monitoring interface defines 256-byte memory map in EEPROM, which makes use of the 8 bit address 1010001X(A2h). Please refer to the SFF-8472 Rev 9.5 for the detail information.