

GPON-OLT-C+

GPON OLT Class C+ SFP Transceiver

FEATURES

- Single fiber bi-directional data links asymmetric TX 2488Mbps/RX1244Mbps application
- 1490nm continuous-mode DFB laser transmitter and 1310nm burst-mode APD-TIA receiver
- Small Form Factor Pluggable package with SC/UPC Connector
- Support Class C+ 17~32dB attenuation range application (With FEC)
- Reset burst-mode receiver design support more than 15dB dynamic range
- 0 to 70°C operating case temperature
- Single 3.3V power supply
- Digital diagnostic monitoring interface
- Digital burst RSSI function to monitor the input optical power level
- LVPECL compatible data input/output interface
- LVTTTL transmitter disable control
- LVTTTL transmitter laser fault alarm
- LVTTTL receiver Signal Detect (SD) indication response within 50ns.
- Low EMI and excellent ESD protection
- Class I laser safety standard IEC-60825 compliant
- RoHS-6 compliance

APPLICATIONS

- Gigabit-capable Passive Optical Networks (GPON) Class C+ 20Km 17~32dB attenuation range

STANDARDS

- Complies with SFP Multi-Source Agreement (MSA) SFF-8074i
- Complies with SFF-8472 Rev 9.5
- Complies with ITU-T G.984.2 Amendment 2
- Complies with FCC 47 CFR Part 15, Class B
- Complies with FDA 21 CFR 1040.10 and 1040.11

ABSOLUTE MAXIMUM RATING

Parameter	Symbol	Min.	Max.	Unit	Notes
Storage Ambient Temperature	T _{STG}	-40	85	°C	
Operating Case Temperature	T _c	0	70	°C	
Operating Humidity	OH	5	95	%	
Power Supply Voltage	V _{CC}	0	4	V	
Receiver Damaged Threshold		+5		dBm	

RECOMMENDED OPERATING CONDITION

Parameter	Symbol	Min.	Typ.	Max.	Unit	Notes
Power Supply Voltage	V _{CC}	3.13	3.3	3.47	V	
Operating Case Temperature	T _c	0		70	°C	
Operating Humidity Range	OH	5		95	%	
Nominal Data Rate			RX 1244.16 TX 2488.32		Mbit/s	

TRANSMITTER OPTICAL CHARACTERISTICS

Parameter	Symbol	Min.	Typ.	Max.	Unit	Notes
Optical Center Wavelength	λ_c	1480		1500	nm	
Optical Spectrum Width (-20dB)	$\Delta\lambda$			1	nm	
Side Mode Suppression Ratio	SMSR	30			dB	
Average Launch Optical Power	AOP	+4		+7	dBm	BOL, Room Temperature
		+3		+7	dBm	EOL, 0~70°C
Power-OFF Transmitter Optical Power				-39	dBm	Launched into SMF
Extinction Ratio	ER	8.2			dB	PRBS 2 ²³ -1+72CID @2.488Gbit/s
Tolerance to Transmitter Incident Light		-15			dB	
Transmitter Reflectance				-10	dB	
Transmitter and Dispersion Penalty	TDP			1	dB	Transmit on 20km SMF
Optical Waveform Diagram		ITU-T G.984.2				Figure 1

TRANSMITTER ELECTRICAL CHARACTERISTICS

Parameter	Symbol	Min.	Typ.	Max.	Unit	Notes
Data Input Differential Swing		600		1600	mV	LVPECL input, AC coupled
Input Differential Impedance		90	100	110	Ω	
Power Supply Current				220	mA	Load free
Transmitter Disable Voltage - Low		0		0.8	V	
Transmitter Disable Voltage - High		2.0		V _{CC}	V	
Transmitter Fault Alarm Voltage - Low		0		0.4	V	
Transmitter Fault Alarm Voltage - High		2.4		V _{CC}	V	

TRANSMITTER EYE MASK DEFINITIONS AND TEST PROCEDURE

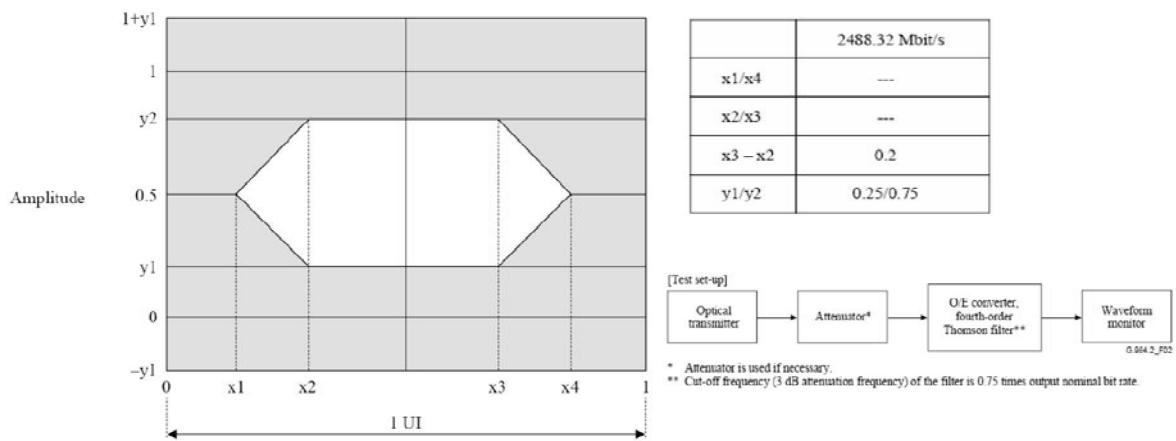

Figure 1 Transmitter Eye Mask Definitions and Test Procedure

RECEIVER OPTICAL CHARACTERISTICS

Parameter	Symbol	Min.	Typ.	Max.	Unit	Notes
Operating Wavelength		1260	1310	1360	nm	
Sensitivity	SEN			-31	dBm	BOL Room Temperature BER $\leq 1 \times 10^{-10}$
				-30	dBm	EOL 0~70°C BER $\leq 1 \times 10^{-10}$
Saturation Optical Power	SAT	-12			dBm	
Dynamic Range		15			dB	Figure 2
Signal Detect Assert Level				-31	dBm	
Signal Detect De-Assert Level		-45			dBm	
Signal Detect Hysteresis		0.5	6		dB	
Receiver Reflectance				-12	dB	

BURST MODE RECEIVER DYNAMIC RANGE IN GPON SYSTEM

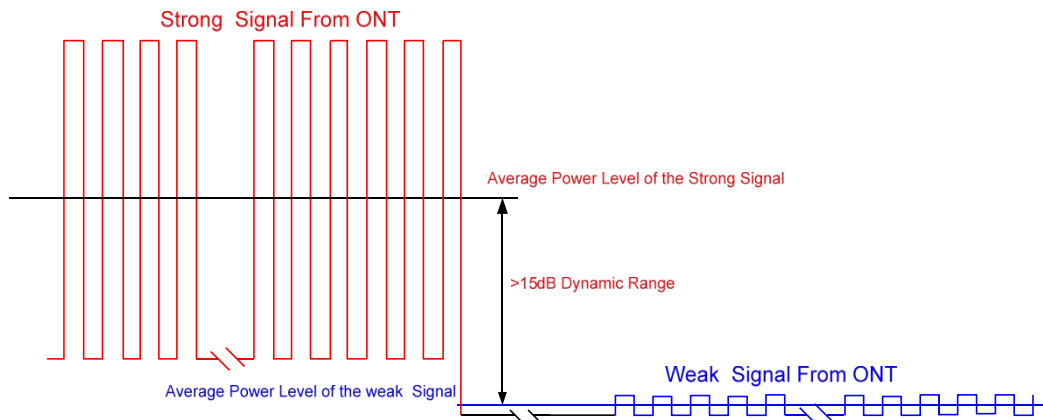

Figure 2 Burst Mode Receiver Dynamic Range in GPON System

RECEIVER ELECTRICAL CHARACTERISTICS

Parameter	Symbol	Min.	Typ.	Max.	Unit	Notes
Power Supply Current				350	mA	Load free
Data Output Voltage – Low (-Vcc)		-1.81		-1.62	V	
Data Output Voltage – High (-Vcc)		-1.02		-0.88	V	
Data Output Differential Swing		400		1600	mV	LVPECL output, DC coupled
Reset width	T _{RESET}	16			bits	
Reset-Low		0		0.4	V	
Reset-High		2.4		Vcc	V	
Receiver Amplitude Recovery	T _{RECOVERY}			32	bits	Refer to the Reset signal falling edge
Signal Detect Assert Time				50	ns	
Signal Detect De-assert Time				12.8	ns	Refer to the Reset signal rising edge
Signal Detect Voltage-Low		0		0.4	V	
Signal Detect Voltage-High		2.4		Vcc	V	
RSSI Trigger-Low		0		0.8	V	
RSSI Trigger-High		2.0		Vcc	V	
Optical Signal During Time	T _{ont}	300			ns	
RSSI Trigger width	T _w	300		T _{ont} -T _D	ns	
RSSI Trigger Delay	T _D	0		3000	ns	
I ² C Access Prohibited Time				500	μs	

TIMING PARAMETER DEFINITIONS IN BURST MODE SEQUENCE

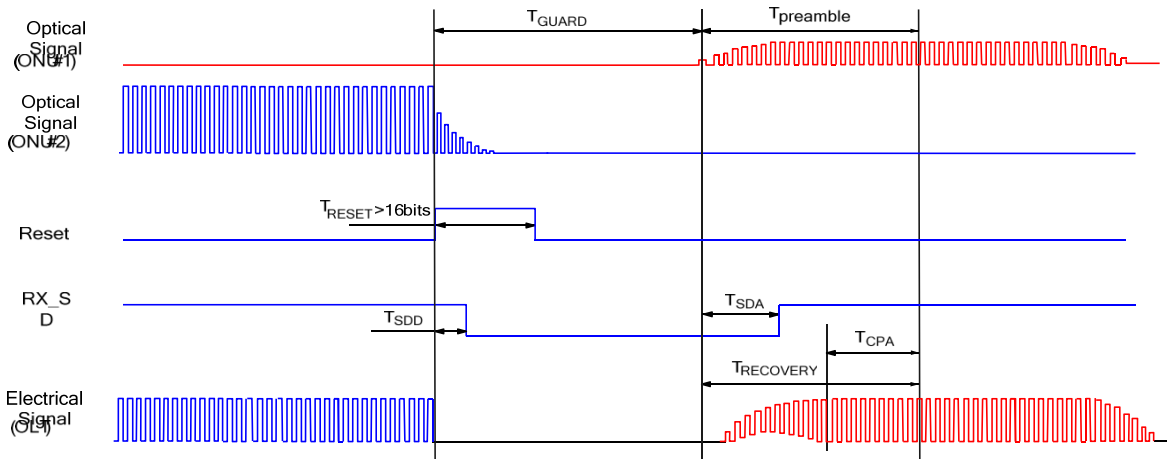

Figure 3 Burst Receiver Timing Sequence

RSSI TIMING SEQUENCE

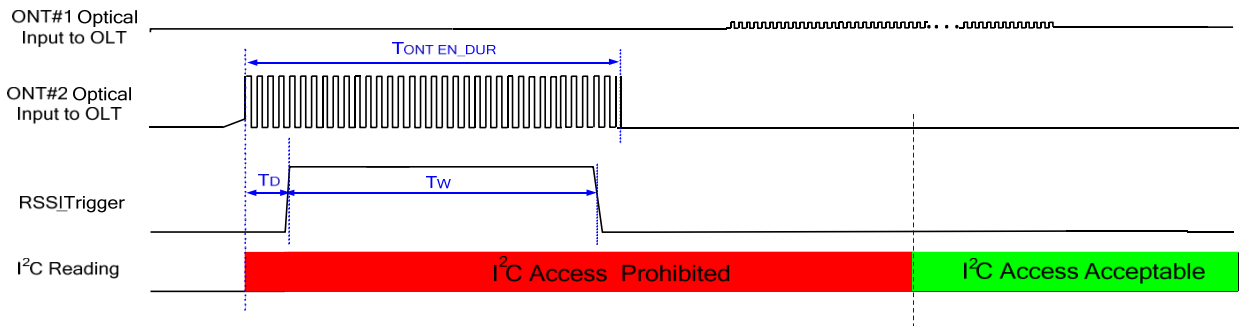

Figure 4 RSSI TIMING SEQUENCE

PIN DESCRIPTION			
PIN	Name	Description	Notes
1	V _{EE} T	Transmitter Ground	
2	TX Fault	Transmitter Fault Indication	High: abnormal; Low: normal
3	TX Disable	Transmitter Disable	High: transmitter disable; Low: transmitter enable
4	MOD-DEF2	Module Definition 2	The data line of two wire serial interface
5	MOD-DEF1	Module Definition 1	The clock line of two wire serial interface
6	MOD-DEF0	Module Definition 0	Connected to Ground in the transceiver
7	Reset	Receiver Reset	High: reset the receiver
8	SD	Signal Detect	High: signal detected; Low: loss of signal;
9	RSSI Trigger	RSSI Trigger for Transceiver A/D Conversion	High: enable RSSI A/D conversion
10	V _{EE} R	Receiver Ground	
11	V _{EE} R	Receiver Ground	

12	RD-	Inv. Receiver Data Out	LVPECL logic output, DC coupled
13	RD+	Receiver Data Out	LVPECL logic output, DC coupled
14	V _{EE} R	Received Ground	
15	V _{CC} R	Receiver Power	
16	V _{CC} T	Transmitter Power	
17	V _{EE} T	Transmitter Ground	
18	TD+	Transmit Data In	LVPECL logic input, AC coupled
19	TD-	Inv. Transmit Data In	LVPECL logic input, AC coupled
20	V _{EE} T	Transmitter Ground	

SFP RECOMMENDED HOST BOARD POWER SUPPLY FILTERING NETWORK

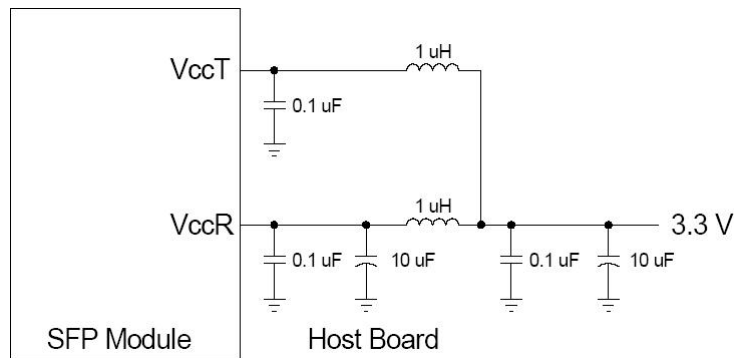

Figure 5 SFP Recommended Host Board Power Supply Filtering Network

SFP PIN (GOLDEN FINGER) DRAWING

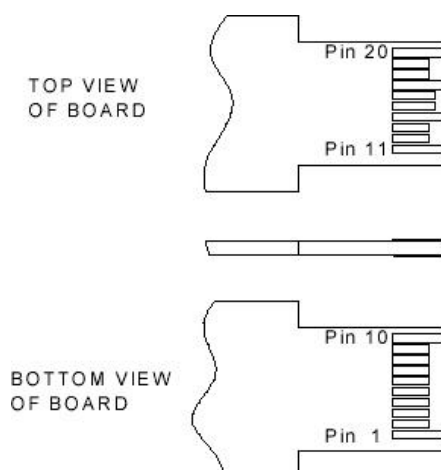

Figure 6 SFP Pin (Golden Finger) Drawing

TYPICAL INTERFACE CIRCUIT

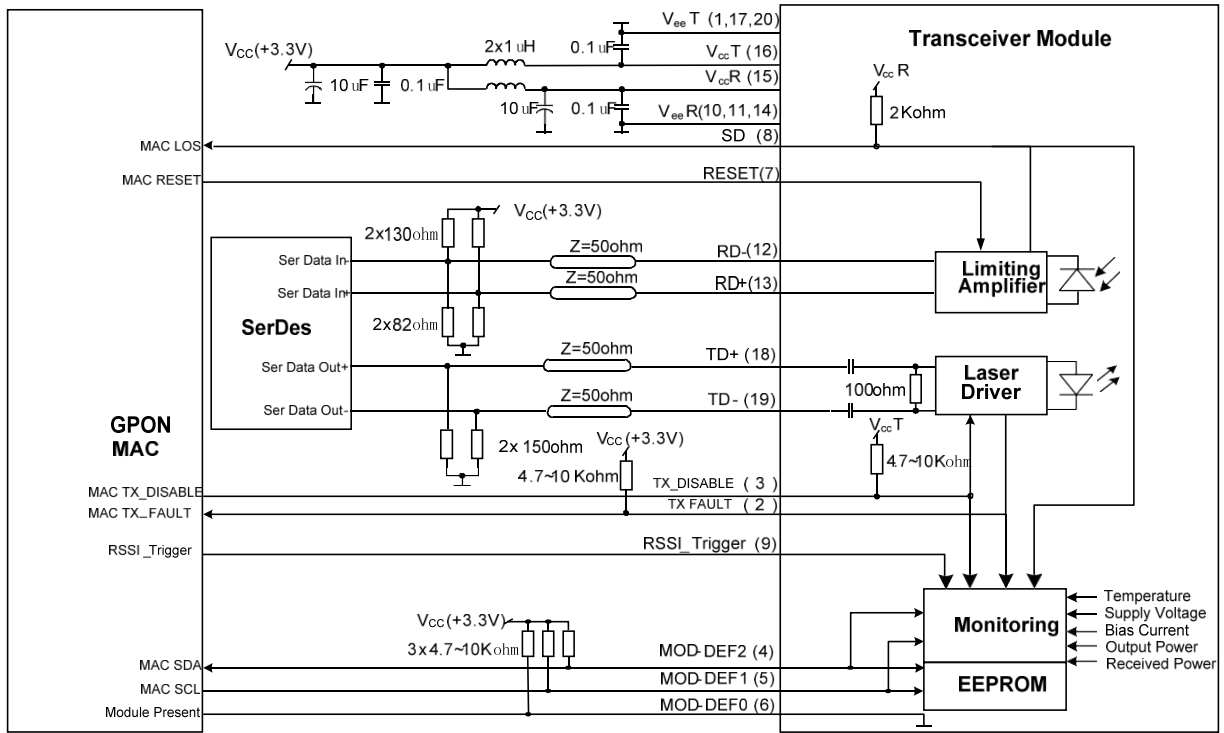

Figure 7 Typical Interface

PACKAGE OUTLINE

Unit: mm

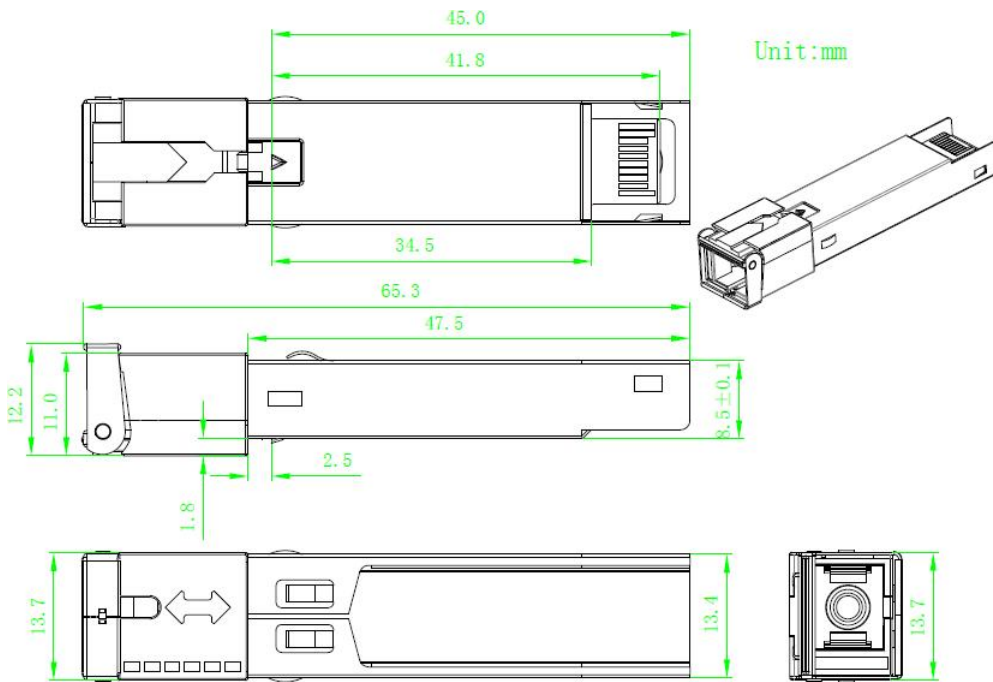

Figure 8 Package Outline

EEPROM INFORMATION

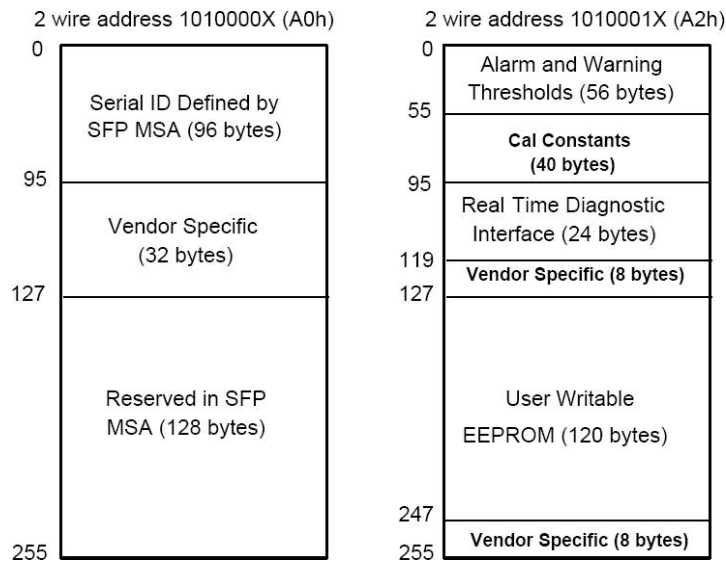

Figure 9 EEPROM Memory Map Specific Data Field Descriptions

DIGITAL DIAGNOSTIC MONITORING INTERFACE

Parameter	Range	Accuracy	Calibration	Note
Temperature	0 to 70°C	±3°C	Internal	1LSB = 1/256°C
Voltage	3.0 to 3.7V	±3%	Internal	1LSB = 0.1mV
Bias Current	0 to 100mA	±10%	Internal	1LSB = 2uA
TX Power	3 to 7dBm	±3dB	Internal	1LSB = 0.1uW
RX Power Monitor	-30 to -10dBm	±3dB	Internal	1LSB = 0.1uW

Note 1: The digital diagnostic monitoring interface defines 256-byte memory map in EEPROM, which makes use of the 8 bit address 1010001X(A2h). Please refer to the SFF-8472 Rev 9.5 for the detail information.

WARNINGS

- **Handling Precautions:** This device is susceptible to damage as a result of electrostatic discharge (ESD). A static free environment is highly recommended. Follow guidelines according to proper ESD procedures.
- **Laser Safety:** Radiation emitted by laser devices can be dangerous to human eyes. Avoid eye exposure to direct or indirect radiation.