



GPON-OLT-C+++

GPON OLT C++ Enhanced Optical Module

Product Features

- Support ITU-T G.984.2 GPON OLT C++ Enhanced application
- Single fiber bi-directional data links with symmetric 2.488Gbps Tx and 1.244Gbps Rx
- 1490nm continuous-mode transmitter with DFB LD
- 1310nm burst-mode receiver with APD-TIA
- 2-wire interface for integrated digital diagnostic Monitoring
- Receiver RESET, Signal Detect, RSSI function indication (RESET, RX_SD, RSSI)
- SFP package with SC/UPC receptacle optical interface
- Single +3.3V power supply
- Operation case temperature 0~70°C
- RoHS6 compliance

Operating Condition

Parameter	Unit	Min.	Typical	Max.
Storage Temperature	°C	-40		85
Operating Case Temp for C-temp	°C	0		70
Operating Relative Humidity	%	5		95
Power Supply Voltage	V	3.15	3.3	3.45
Supply Current	mA			600
Bit Rate for Tx	Gbps		2.488	
Bit Rate for Rx	Gbps		1.244	

Characteristics

All performance is specified at whole working temperature and conditions

Parameter	Unit	Min.	Typical	Max.
Transmitter				
TX Central Wavelength	nm	1480	1490	1500
Spectral Width (-20dB)	nm			1
Side Mode Suppression Ratio (SMSR)	dB	30		
Mean Launched Power (BOL)	dBm	7	7.5	10
Mean Launched Power (TX Off)	dBm			-45
Extinction Ratio	dB	8.2		
Optical Return Loss Tolerance	dB	-12		
Transmitter and dispersion Penalty	dB			1

Transmitter Mask(PRBS2 ²³ -1@2.488G)	Compliant With ITU-T G.984.2			
Receiver				
Receive Wavelength	nm	1290	1310	1330
Sensitivity (BOL) (PRBS2 ²³ -1@1.244G,ER=10,BER<10 ⁻⁴)	dBm			-33
Sensitivity (BOL) (PRBS2 ²³ -1@1.244G,ER=10,BER<10 ⁻¹⁰)	dBm			-31
Overload (PRBS2 ²³ -1@1.244G,ER=10,BER<10 ⁻¹⁰)	dBm	-12		
Receiver Burst Mode Dynamic Range	dB	15		
Damage Threshold for Receiver	dBm	5		
SD Assert Level	dBm			-33
SD De-assert Level	dBm	-45		
SD Hysteresis	dB	0.5		6
WDM Filter isolation to 1550nm	dB	38		
WDM Filter isolation to 1650nm	dB	35		
Electrical Interface Characteristics				
Data Input Swing Differential/TX	mV	200	-	2000
Data Output Swing Differential/RX	mV	400		1600
Date Differential Impedance	Ω	90	100	110
LVTTL Output High	V	2.4		V _{cc}
LVTTL Output Low	V	0		0.4
LVTTL Input High	V	2.0		V _{cc} +0.3
LVTTL Input Low	V	0		0.8
Timing Characteristics				
Guard Time (T _g)	ns	25.6		
Reset Pulse Width (T _r)	ns			12.8
Reset Delay (T _{rd})	ns			12.8
Receiver Preamble Time (T _p)	ns			140
SD Assert Time (T _{SDA})	ns			100
SD De-assert Time (T _{SDD})	ns			12.8
RSSI Trigger Delay (T _{td})	ns	25		
RSSI Trigger Pulse Width (T _w)	ns	500		
Internal I2C Delay (T _{wait})	us			500

Timing Sequence for RSSI

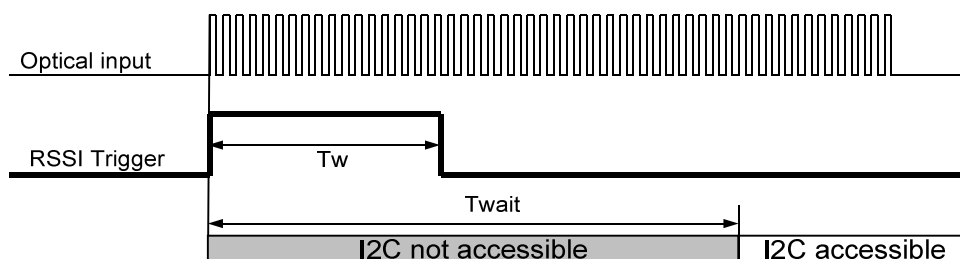

Timing Sequence for Ranging Mode

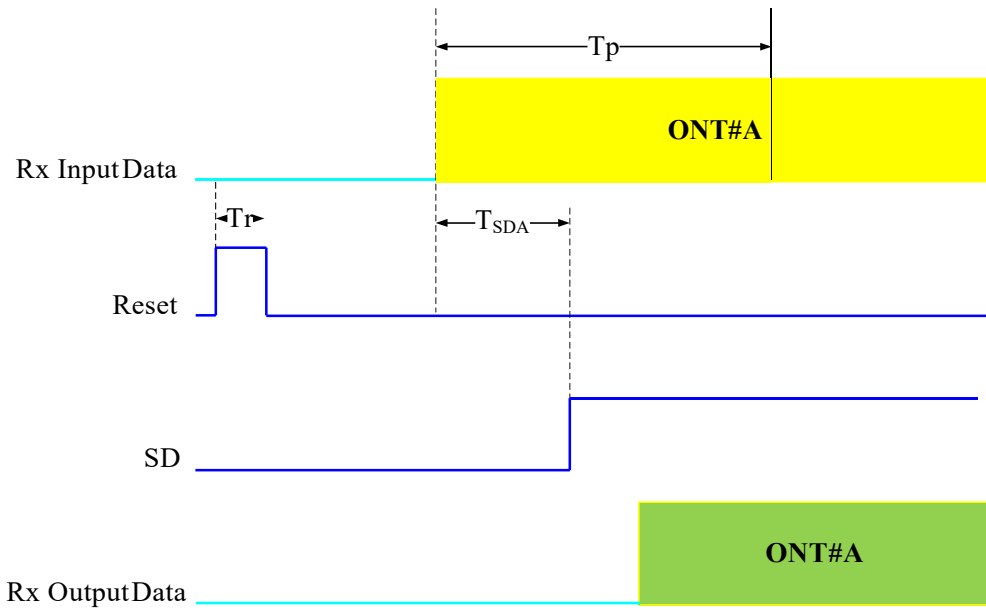

Timing Sequence for Working Mode

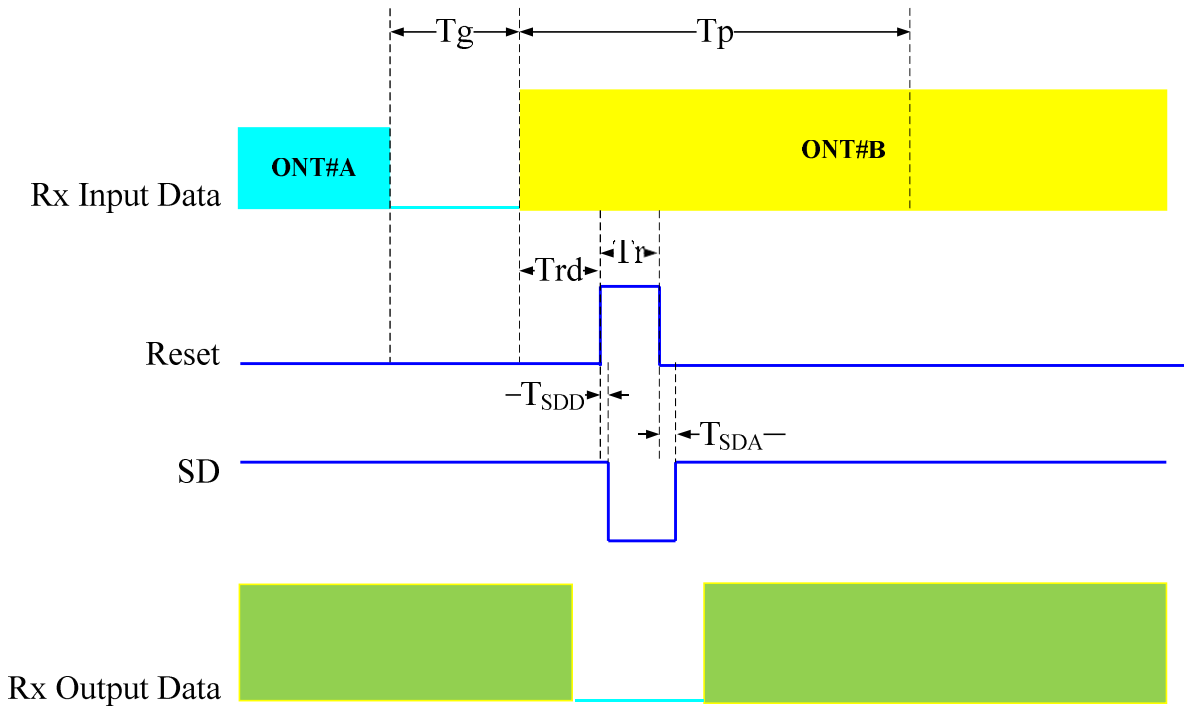

Pin Definitions

Pin No.	Symbol	Level / Logic	Description
1	VeeT		Module Transmitter Ground
2	Tx_Fault	LVTTL-O	Module Transmitter Fault
3	Tx_DIS	LVTTL-I	Laser output is disabled when this pin is asserted high or left unconnected
4	SDA	LVTTL-I	2-Wire Serial Interface Data Line
5	SCL	LVTTL-I/O	2-Wire Serial Interface Clock
6	MOD_ABS	LVTTL-O	Module Absent, connected to ground in the module
7	RX_Reset	LVTTL-I	Receiver RESET signal
8	RX_SD	LVTTL-O	Receiver Signal Detected Indication
9	RSSI_TRIG	LVTTL-I	Receiver RSSI Trigger signal
10	VeeR		Module Receiver Ground
11	VeeR		Module Receiver Ground
12	RD-	LVPECL-O	Receiver Inverted Data Output
13	RD+	LVPECL-O	Receiver Non-Inverted Data Output
14	VeeR		Module Receiver Ground
15	VccR		Module Receiver 3.3V Supply
16	VccT		Module Transmitter 3.3V Supply
17	VeeT		Module Transmitter Ground
18	TD+	LVPECL-I	Transmitter Non-Inverted Data Input
19	TD-	LVPECL-I	Transmitter Inverted Data Input
20	VeeT		Module Transmitter Ground

Recommended Interface Circuit

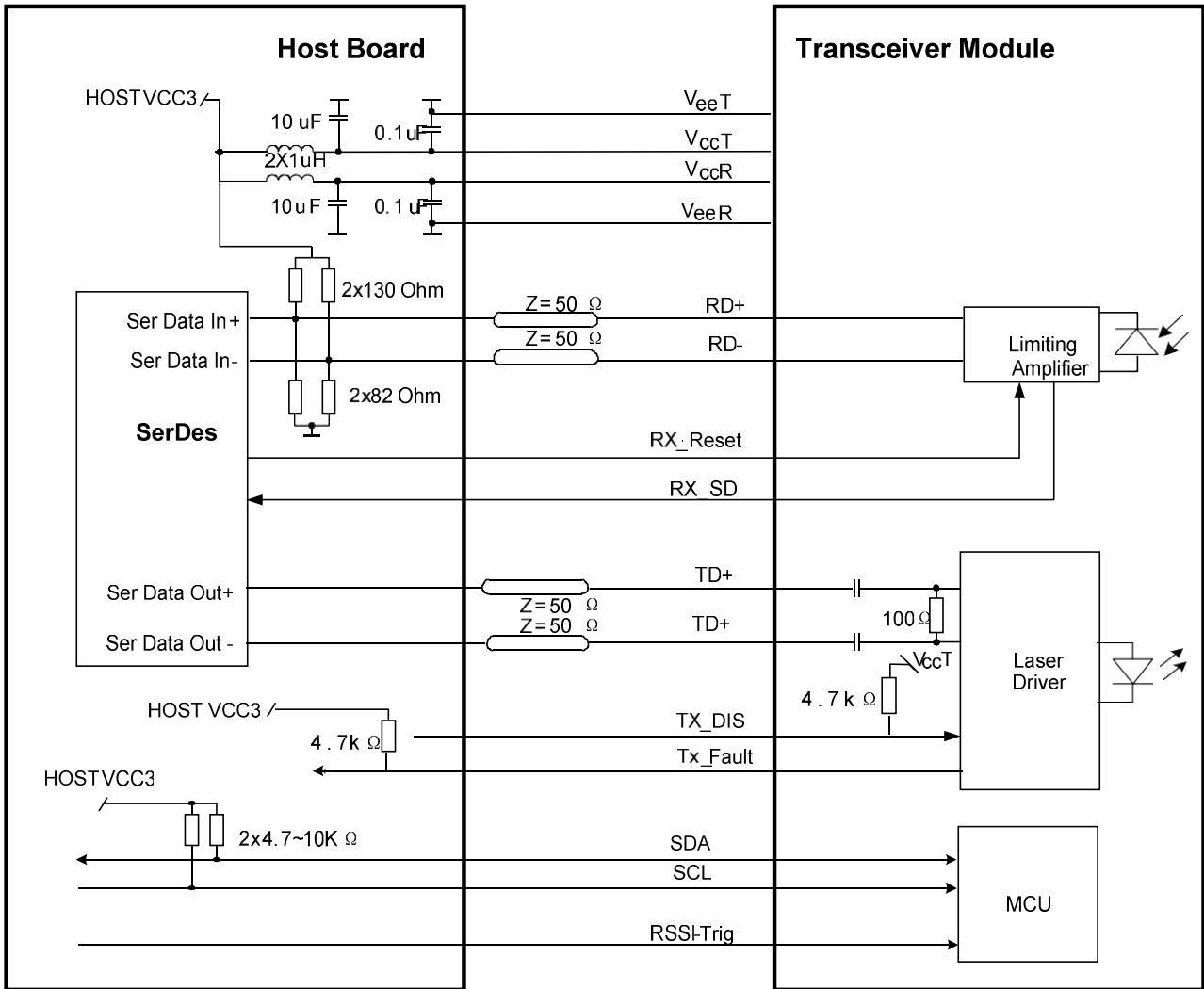

Mechanical Diagram

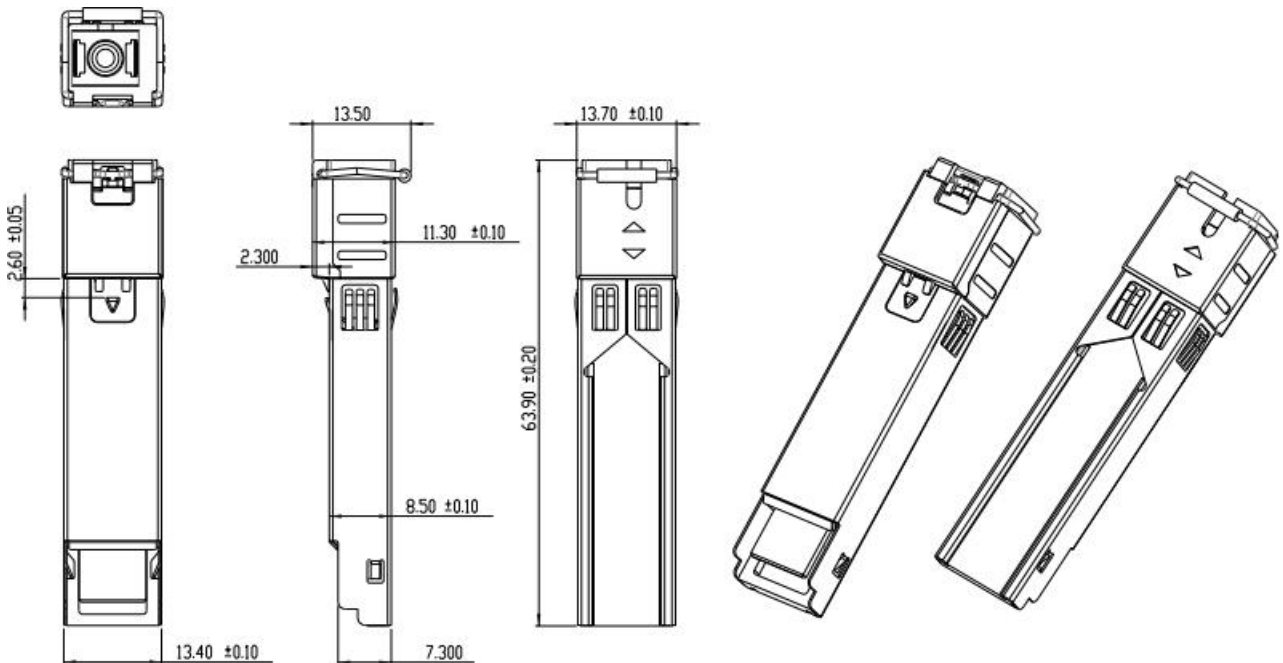



EEPROM Information

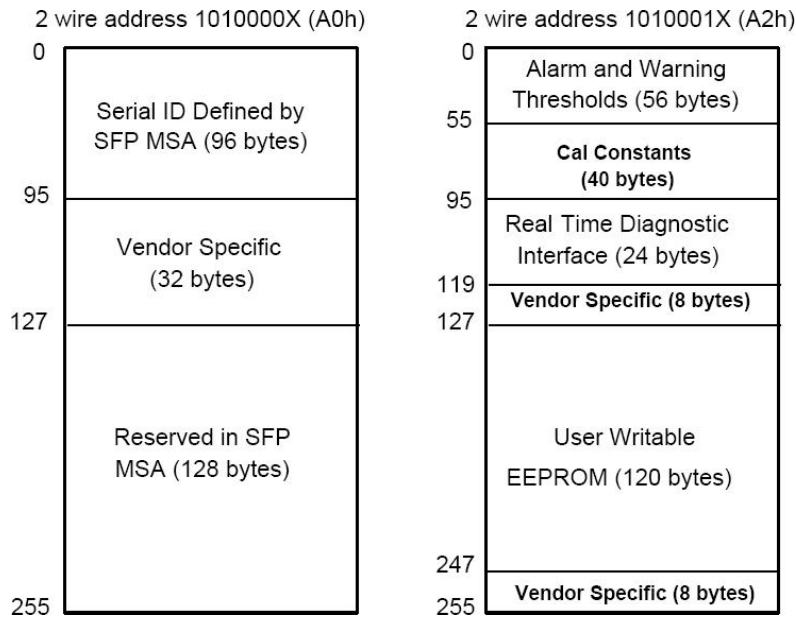

Ordering Information

Ordering P/Ns	Description
GPON-OLT-C+++	GPON OLT C++ Enhanced, 20km, TX 1490nm 2.488Gbps (7dBm), RX 1310nm 1.244Gbps (-31dBm), SFP form-factor, SC/UPC Receptacle, 0~70°C Commercial Temperature, V2 version mechanical housing

Version	Date	Description
V0	Mar-1-2017	New release