

10G-XENPAK-LR-20

10 Gigabit XENPAK Transceiver

FEATURES

- XAUI Electrical Interface: 4 Lanes @ 3.125Gbit/s
- Uncooled 1310nm DFB
- Hot Z-Pluggable
- SC-Duplex Optical Receptacle
- MDIO, DOM Support
- Pin Photo-detector
- Compliant to XENPAK MSA
- Compliant to IEEE 802.3ae 10GBASE-LR Application
- Case operating temperature: 0 to 70 °C

REFERENCE

IEEE 802.3ae as 10GBASE-LR, XENPAK MSA Release3.0

GENERAL DESCRIPTION

Sate Optics's 10Gb/s XENPAK transceiver module 10G-XENPAK-LR-20 is a hot pluggable in the Z-direction module that is usable in typical router line card applications, Storage, IP network and LAN and compliant to XENPAK MSA. The 10G-XENPAK-LR-20 is a fully integrated 10.3Gbit/s optical transceiver module that consists of a 10.3Gbit/s optical transmitter and receiver, XAUI interface, Mux and Demux with clock and data recovery(CDR).This version of Sate Optics Inc. transceiver line uses an uncooled 1310nm DML Laser Diode to achieve 20km over standard single mode fiber as 10GBASE-LR of the IEEE 802.3ae.

I .Optical Characteristics

Table1. Optical Characteristics

No.	Parameters	Symbols	Min.	Typ.	Max.	Unit	Remarks
1	Center Wavelength	λ_C	1290	1310	1330	nm	
2	Signaling speed		-	10.3125	-	Gbit/s	
3	Signaling speed variation from nominal		-100	-	+100	ppm	
4	Average Optical Power	Pf	-5.0	-	0.5	dBm	
5	Side Mode Suppression Ratio	Sr	30	-	-	dB	Average
6	Extinction Ratio	Er	3.5	-	-	dB	
7	Off Transmit Power	Poff	-	-	-30	dBm	Average
8	Receiver Sensitivity	Rsense	-		-15	dBm	
9	Receiver Overload	Rro	+0.5	-	-	dBm	Average
10	Optical Centre Wavelength	λ_C	1270		1610	nm	
11	Los D-Assert	ROSD			-18	dBm	
12	Los Assert	ROSA	-32				
13	Los Hysteresis		0.5	-	-	dB	

II .Electrical Performance

Table2. Power Supply Characteristics

No.	Parameter	Symbol	Min.	Typ.	Max.	Unit	Remarks
1	Supply Voltage	VCC1	3.135	3.300	3.465	V	
2	Supply Voltage	VCC2	1.152	1.200	1.248	V	
3	Supply Current	ICC1	-	-	1.0	A	+3.3 V
4	Supply Current	ICC2	-	-	1.7	A	APS
5	Power Consumption	PDS	-	-	4.0	W	
6	Power supply stabilization time	TDF	-	-	500	ms	
7	Initialization Time	TINIT	-	-	5	s	
8	RESET Assert Time	TRESET	1	-	-	ms	
9	Hold Time after rising edge of RESET	THOLD	500	-	-	ms	

Table3. XAUI Driver Characteristics

No.	Parameter	Symbol	Min.	Typ.	Max.	Unit	Remarks
1	Baud Rate		-	3.125	-	Gbit/s	
2	Baud Rate Tolerance		-100	-	+100	ppm	
3	Differential Amplitude		800	-	1600	mVPP	AC, near-end value

Table4. 1.2V CMOS Interface Characteristics

No.	Parameter	Symbol	Min.	Typ.	Max.	Unit	Remarks
1	Input High Voltage	VIH	0.84	-	1.5	V	
2	Input Low Voltage	VIL	-0.3	-	0.36	V	
3	Input Pull-down Current	IIn	20	40	120	μA	Vih=1.2V
4	Output High Voltage	VOH	1.0	-	-	V	Pull-up=10k ohm to 1.2V
5	Output Low Voltage	VOL	-	-	0.2	V	
6	Pull up Resistance	RLASI	10	-	22	k ohm	
7	Capacitance	CLASI	-	-	10	pF	
8	Load Capacitance	CLoad	-	-	320	pF	

Table5. MDIO Bidirectional Interface Characteristics

No.	Parameter	Symbol	Min.	Typ.	Max.	Unit	Remarks
1	Input High Voltage	VIHM	0.84	-	1.5	V	
2	Input Low Voltage	VILM	-0.3	-	0.36	V	
3	Output High Voltage	VOHM	1.0	-	1.5	V	
4	Output Low Voltage	VOLM	-0.3	-	0.2	V	
5	Pull up Resistance	RMDIO	200	-		Ohm	
6	MDC min high/low time	THM,TLM	160	-	-	ns	
7	MDC Frequency	1/TCK	TBD	-	2.5	MHz	
8	Setup time	TDIS	10	-	-	ns	
9	Hold time	TDIH	10	-	-	ns	
10	MDIO output delay after rising edge of MDC	TPD	0	-	300	ns	
12	Input Capacitance	Ci	-	-	10	pF	
13	Bus Loading	CL	-	-	470	pF	

Note: The maximum value of RMDIO depends on bus loading(CL) , input capacitance(Ci), and MDC frequency(1/TCK).

III. Electrical Pad Layout

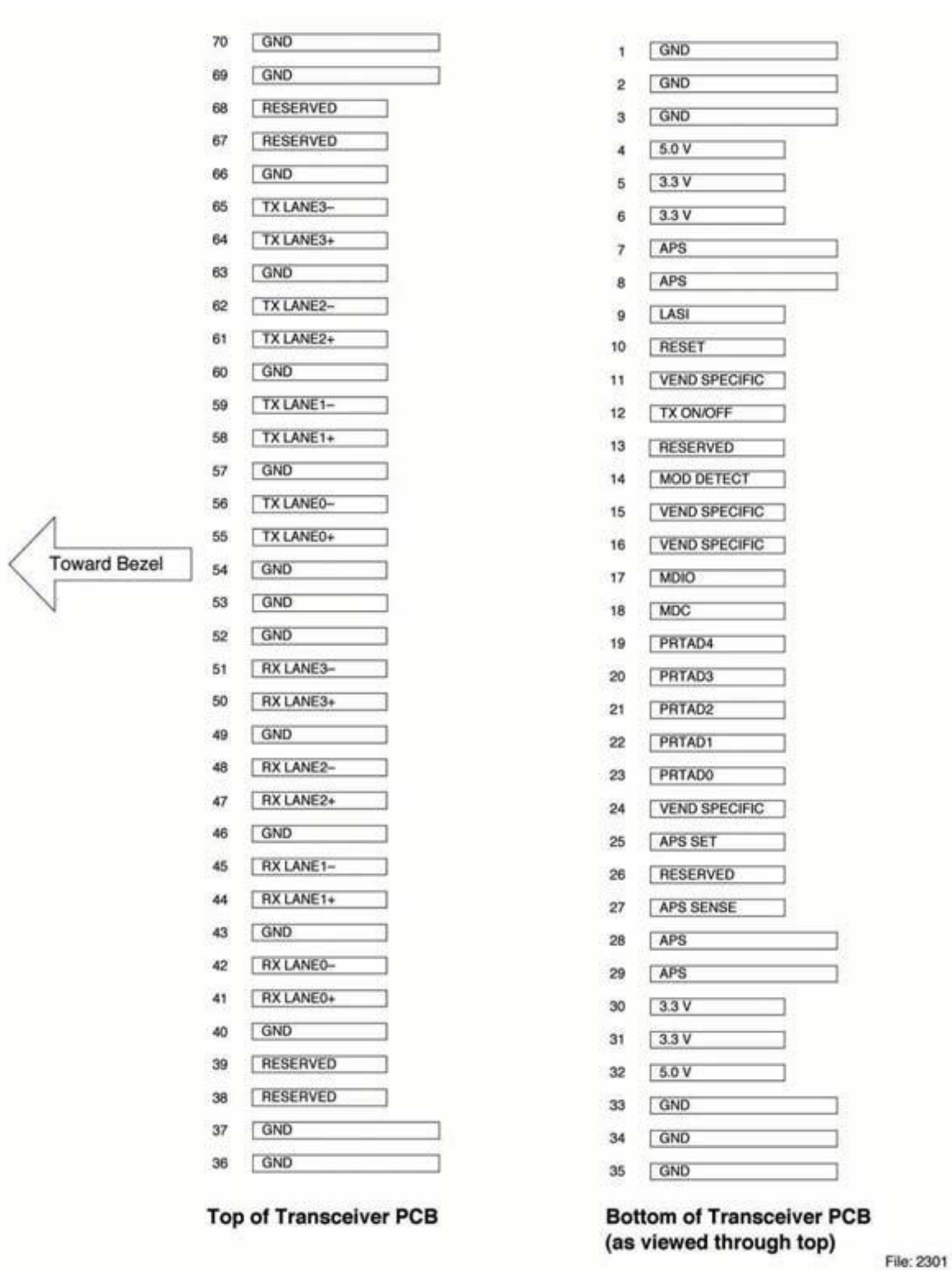

Fig 1-XENPAK Transponder Electrical Pad Layout

Table6. XENPAK Pin Configuration

Pin #	Symbol	I/O	Logic	Description
1	GND	I	Supply	Electrical ground
2	GND	I	Supply	Electrical ground
3	GND	I	Supply	Electrical ground
4	RESERVED	-	-	Reserved
5	3.3 V	I	Supply	Power
6	3.3 V	I	Supply	Power
7	APS	I	Supply	Adaptive Power Supply
8	APS	I	Supply	Adaptive Power Supply
9	LASI	O	Open Drain	Link Alarm Status Interrupt. 10-22k ohm pull up on host.
10	RESET	I	1.2V CMOS	TX OFF when MDIO RESET
11	VEND SPECIFIC	-	-	Vendor Specific Pin. Leave unconnected.
12	TX ON/OFF	I	1.2V CMOS	Transmitter ON/OFF
13	RESERVED	-	-	Reserved
14	MOD DETECT	O	-	Pulled low inside module through 1k ohm.
15	VEND SPECIFIC	-	-	Vendor Specific Pin. Leave unconnected.
16	VEND SPECIFIC	-	-	Vendor Specific Pin. Leave unconnected.
17	MDIO	I/O	Open Drain	Management Data IO
18	MDC	I	1.2V CMOS	Management Data Clock
19	PRTAD4	I	1.2V CMOS	Port Address bit 4 (Low=0)
20	PRTAD3	I	1.2V CMOS	Port Address bit 3 (Low=0)
21	PRTAD2	I	1.2V CMOS	Port Address bit 2 (Low=0)
22	PRTAD1	I	1.2V CMOS	Port Address bit 1 (Low=0)
23	PRTAD0	I	1.2V CMOS	Port Address bit 0 (Low=0)
24	VEND SPECIFIC	-	-	Vendor Specific Pin. Leave unconnected.
25	APS SET	O	-	Feedback output for APS
26	RESERVED	-	-	Reserved for Avalanche Photodiode use.
27	APS SENSE	O	Analog	APS Sense Connection
28	APS	I	Supply	Adaptive Power Supply
29	APS	I	Supply	Adaptive Power Supply
30	3.3 V	I	Supply	Power
31	3.3 V	I	Supply	Power
32	RESERVED	-	-	Reserved
33	GND	I	Supply	Electrical Ground
34	GND	I	Supply	Electrical Ground
35	GND	I	Supply	Electrical Ground
36	GND	I	Supply	Electrical Ground
37	GND	I	Supply	Electrical Ground
38	RESERVED	-	-	Reserved

39	RESERVED	-	-	Reserved
40	GND	I	Supply	Electrical Ground
41	RX LANE 0+	O	AC	Module XAUI Output Lane 0+
42	RX LANE 0-	O	AC	Module XAUI Output Lane 0-
43	GND	I	Supply	Electrical Ground
44	RX LANE 1+	O	AC	Module XAUI Output Lane 1+
45	RX LANE 1-	O	AC	Module XAUI Output Lane 1-
46	GND	I	Supply	Electrical Ground
47	RX LANE 2+	O	AC	Module XAUI Output Lane 2+
48	RX LANE 2-	O	AC	Module XAUI Output Lane 2-
49	GND	I	Supply	Electrical Ground
50	RX LANE 3+	O	AC	Module XAUI Output Lane 3+
51	RX LANE 3-	O	AC	Module XAUI Output Lane 3-
52	GND	I	Supply	Electrical Ground
53	GND	I	Supply	Electrical Ground
54	GND	I	Supply	Electrical Ground
55	TX LANE 0+	I	AC	Module XAUI Input Lane 0+
56	TX LANE 0-	I	AC	Module XAUI Input Lane 0-
57	GND	I	Supply	Electrical Ground
58	TX LANE 1+	I	AC	Module XAUI Input Lane 1+
59	TX LANE 1-	I	AC	Module XAUI Input Lane 1-
60	GND	I	Supply	Electrical Ground
61	TX LANE 2+	I	AC	Module XAUI Input Lane 2+
62	TX LANE 2-	I	AC	Module XAUI Input Lane 2-
63	GND	I	Supply	Electrical Ground
64	TX LANE 3+	I	AC	Module XAUI Input Lane 3+
65	TX LANE 3-	I	AC	Module XAUI Input Lane 3-
66	GND	I	Supply	Electrical Ground
67	RESERVED	-	-	Reserved
68	RESERVED	-	-	Reserved
69	GND	I	Supply	Electrical Ground
70	GND	I	Supply	Electrical Ground

Note: Case is connected to electrical ground in the module.

IV. Package Outline

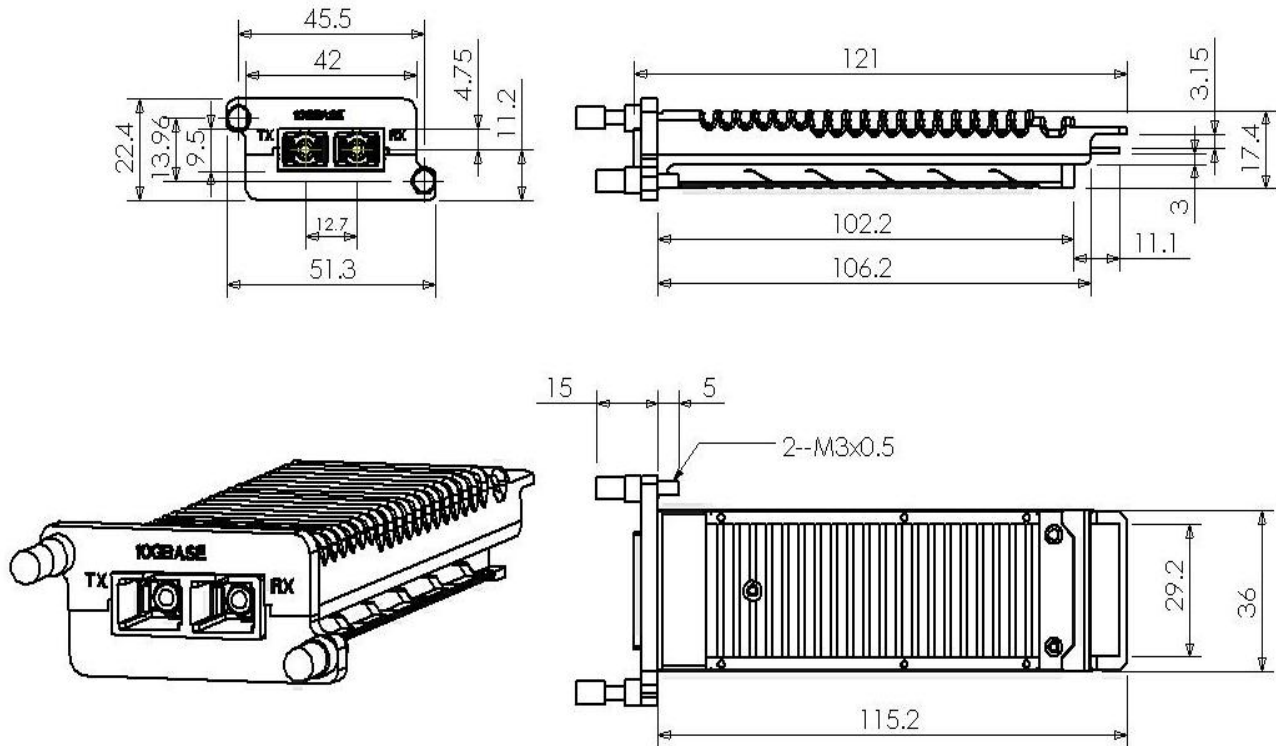

Figure 1 Mechanical dimensions

V. Register Definition

Device Address (Dec) Register Address (Hex)	PMA/PMD 1	PCS 3	PHY XS 4
0x0000	PMA/PMD Control1	PCS Control1	PHY TSControl1
0x0001	PMA/PMD Status1	PCS Status1	PHY TS Status1
0x0002	PMA/PMD Device Identifier0	PCS Device Identifier0	PHY TSDevice Identifier0
0x0003	PMA/PMD Device Identifier1	PCS Device Identifier1	PHY TS Device Identifier1
0x0004	PMA/PMD Speed Ability	PCS Speed Ability	PHY TS Speed Ability
0x0005	PMA/PMD Device in Package1	PCS Device in Package1	PHY XS Device in Package1
0x0006	PMA/PMD Device in Package2	PCS Device in Package2	PHY XS Device in Package2
0x0007	10G PMA/PMD Control2	PCS Control2	Reserved
0x0008	10G PMA/PMD Status2	PCS Status2	PHY TSStatus2
0x0009	10G PMD Transmit Disable	Reserved	Reserved
0x000A	10G PMD Receive Signal O.K.	Reserved	Reserved
0x000E	Package Identifier0	Reserved	Reserved
0x000F	Package Identifier1	Reserved	Reserved
0x0018	Reserved	Reserved	10G PHY TS Lane Status

0x0019	Reserved	Reserved	10G PHY TS Test Control
0x0020	Reserved	10GBASE-R PCS Status1	Reserved
0x0021	Reserved	10GBASE-R PCS Status2	Reserved
0x0022	Reserved	10GBASE-R PCS Test pattern Seed A0	Reserved
0x0023	Reserved	10GBASE-R PCS Test pattern Seed A1	Reserved
0x0024	Reserved	10GBASE-R PCS Test pattern Seed A2	Reserved
0x0025	Reserved	10GBASE-R PCS Test pattern Seed A3	Reserved
0x0026	Reserved	10GBASE-R PCS Test pattern Seed B0	Reserved
0x0027	Reserved	10GBASE-R PCS Test pattern Seed B1	Reserved
0x0028	Reserved	10GBASE-R PCS Test pattern Seed B2	Reserved
0x0029	Reserved	10GBASE-R PCS Test pattern Seed B3	Reserved
0x002A	Reserved	10GBASE-R PCS Test pattern Control	Reserved
0x002B	Reserved	10GBASE-R PCS Test pattern Error counter	Reserved
0x8000	NVR Control/Status (XENPAK Register)	Reserved	
0x8007 - 0x807D	NVR (XENPAK Register)	Reserved	
0x807E-0x80AD	Customer AREA	Reserved	
0x80AE - 0x8106	Sate Optics Specific Area(XENPAK Register)	Reserved	
0x9000	RX_ALARM Control (XENPAK Register)	Reserved	
0x9001	TX_ALARM Control (XENPAK Register)	Reserved	
0x9002	LASI Control (XENPAK Register)	Reserved	
0x9003	RX_ALARM Status (XENPAK Register)	Reserved	
0x9004	TX_ALARM Status (XENPAK Register)	Reserved	
0x9005	LASI Status (XENPAK Register)	Reserved	
0x9006	TX_FLAG Control Bits	Reserved	
0x9007	RX_FLAG Control Bits	Reserved	
0xA000 - 0xA027	Alarm and Warning Thresholds	Reserved	
0xA060 - 0xA069	Digital Optical Monitoring Interface	Reserved	
0xA06F	DOM Capability - Extended	Reserved	
0xA070	TX_ALARM_FLAG Bits	Reserved	
0xA071	RX_ALARM_FLAG Bits	Reserved	
0xA074	TX_WARNING_FLAG Bits	Reserved	
0xA075	RX_WARNING_FLAG Bits	Reserved	
0xA100	Optional Digital Optical Monitoring (DOM) Control/Status	Reserved	

VI. Regulatory Compliance

Feature	Reference	Performance
Electrostatic discharge (ESD)	IEC/EN 61000-4-2	Compatible with standards
Electromagnetic Interference (EMI)	FCC Part 15 Class B EN 55022 Class B (CISPR 22A)	Compatible with standards
Laser Eye Safety	FDA 21CFR 1040.10, 1040.11 IEC/EN 60825-1, 2	Class 1 laser product
ROHS	2002/95/EC	Compatible with standards
EMC	EN61000-3	Compatible with standards

Appendix A. Document Revision

Version No.	Date	Description
1.0	2010-09-01	Preliminary datasheet
2.0	2011-09-10	Update format and company's logo