

25G-SFP28-SR

25G SFP28 SR Dual LC Transceivers

PRODUCT FEATURES

- 25Gbps serial optical interface
- 850nm VCSEL transmitter and GaAs PIN PD receiver
- Rate Adaptation
- Operating temperature :
 - Commercial (0°C~ 70°C)
 - Industrial (-40°C~ 85°C)
- Maximum link length of 70m via OM3 multimode Fiber (MMF)
- Maximum link length of 100m via OM4 multimode Fiber (MMF)



Application

- Inter Rack Connection
- High-speed Servers
- High-performance Computing Clusters
- SAN, Routers, Hubs, Load Balancer

Ordering information

Part Number	Product Description
25G-SFP28-SR	25G SFP28 SR Transceivers, C-TEMP
25G-SFP28-SR-I	25G SFP28 SR Transceivers, I-TEMP

DESCRIPTION

The 25G-SFP28-SR Transceiver is intended for 100m reach service 25.78Gb/s 850nm Multi-mode high-speed communications equipment where low-cost, extraordinary performance and reliability are essential. It consumes low power, operates base on 3.3V DC power supply and is offered in the commercial/industrial temperature range. They are compliant with SFP28 MSA, SFF-8431 and SFF- 8432.

The low jitter and low bit error rate optical assembly features a DML laser transmitter and PIN/TIA receiver. It utilizes internal clock and data recovery (CDR) units on transmitter and the receiver chains for low jitter compliance. The differential AC coupled Tx and Rx data interfaces are CML compatible. The device is Class I laser safety compliant.



ABSOLUTE MAXIMUM RATINGS

Parameter	Symbol	Conditions	Min.	Max.	Unit
Storage Temperature	T _{Storage}		-40	+85	°C
Relative Humidity	RH		0	+85	%

RECOMMENDED OPERATING CONDITIONS

Parameter	Symbol	Conditions	Min.	Typ.	Max.	Unit
Case Temperature	T _C	25G-SFP28-SR	0		70	°C
		25G-SFP28-SR-I	-40		85	
Power Supply Voltage	V _{CC}		3.15	3.30	3.45	V
Bit Rate	BR			25.78125		Gbps

ELECTRICAL CHARACTERISTICS

Parameter	Symbol	Conditions	Min.	Typ.	Max.	Unit
Power Consumption					1	W
Supply Current	I _{CC}				300	mA

TRANSMITTER CHARACTERISTICS

Parameter	Symbol	Conditions	Min.	Typ.	Max.	Unit
Center wavelength	λ		840		860	nm
RMS spectral width	P _m				0.6	nm
Average optical power	P _{avg}		-5		2.4	dBm
Optical modulation amplitude	OMA		-5		3	dBm
Average launch power of OFF transmitter	P _{off}				-30	dBm
Extinction ratio	ER		3			dB
Optical return loss tolerance					12	dB

RECEIVER CHARACTERISTICS

Parameter	Symbol	Conditions	Min.	Typ.	Max.	Unit
Center wavelength	λ		840	850	860	nm
Damage threshold			3.4			dBm
Receive power overload			2.4			dBm
Receiver reflectance					-12	dB
Receiver sensitivity	SENS	Note1			-5	dBm
Receiver sensitivity	SENS	Note2			-10	dBm
LOS Assert	LOS _A		-30			dBm
LOS De-Assert	LOS _D				-13	dBm
LOS Hysteresis	LOSH		0.5			dB

Note1. Measured with a 25.78125G, PRBS-31 NRZ, ER>3.5dB, BER<1E-12.

Note2. Measured with a 25.78125G, PRBS-31 NRZ, ER>3.5dB, BER<5E-5.

PIN ASSIGNMENT

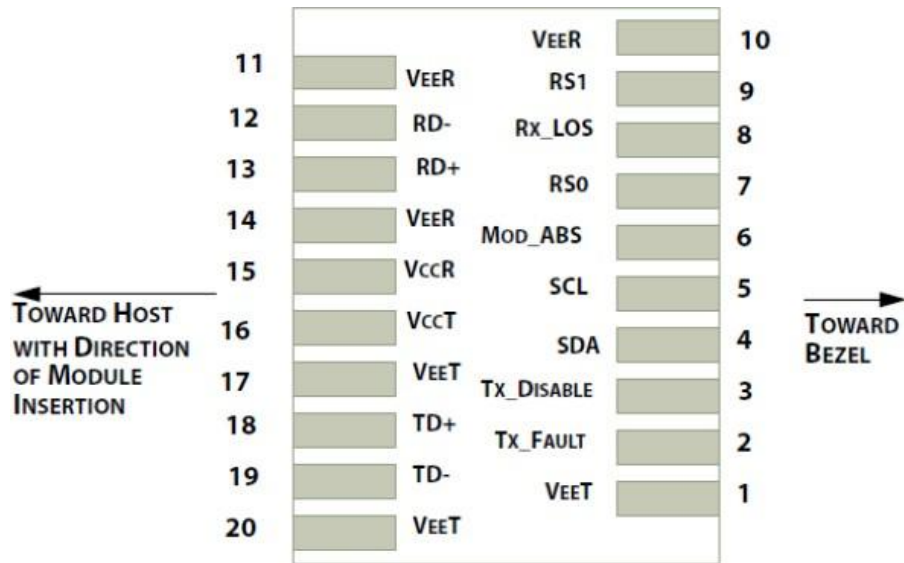

PIN DESCRIPTION

PIN	Logic	Symbol	Name / Description
1		VeeT	Module Transmitter Ground
2	LVTTTL-O	TX_Fault	Module Transmitter Fault
3	LVTTTL-I	TX_Dis	Transmitter Disable; Turns off transmitter laser output
4	LVTTTL-I/O	SDA	2-Wire Serial Interface Data Line
5	LVTTTL-I	SCL	2-Wire Serial Interface Clock
6		MOD_DEF0	Module Definition, Grounded in the module
7	LVTTTL-I	RS0	Receiver Rate Select
8	LVTTTL-O	RX_LOS	Receiver Loss of Signal Indication Active LOW
9	LVTTTL-I	RS1	Transmitter Rate Select (not used)
10		VeeR	Module Receiver Ground
11		VeeR	Module Receiver Ground
12	CML-O	RD-	Receiver Inverted Data Output
13	CML-O	RD+	Receiver Data Output
14		VeeR	Module Receiver Ground
15		VccR	Module Receiver 3.3 V Supply
16		VccT	Module Receiver 3.3 V Supply
17		VeeT	Module Transmitter Ground
18	CML-I	TD+	Transmitter Non-Inverted Data Input
19	CML-I	TD-	Transmitter Inverted Data Input
20		VeeT	Module Transmitter Ground

Recommended Interface Circuit

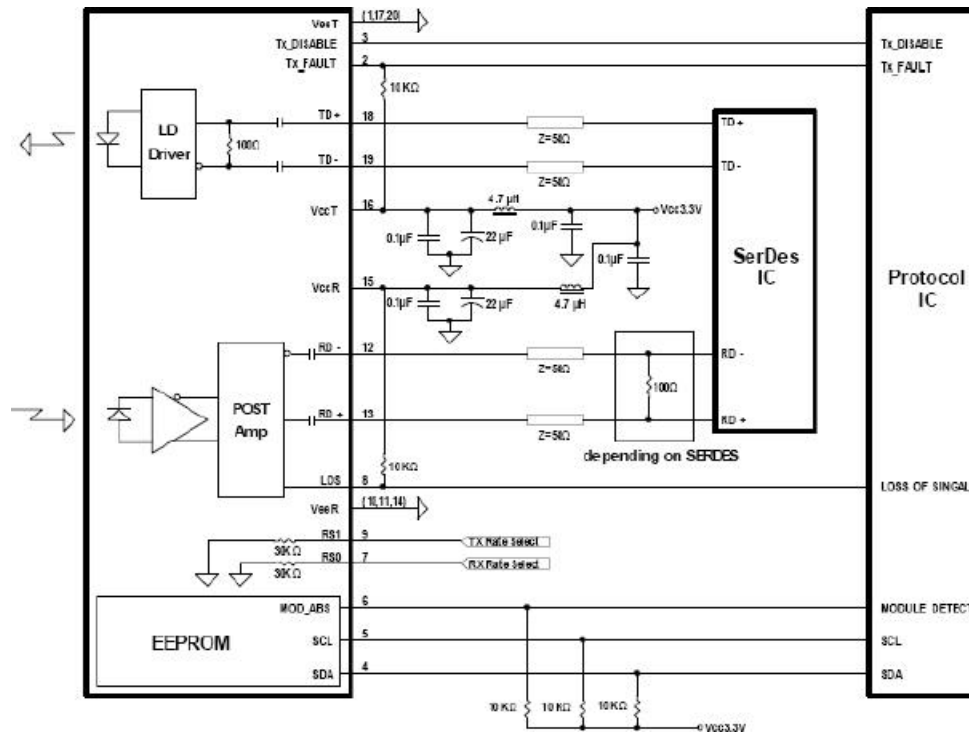

Figure 2. Typical application circuit

Mechanical Dimensions

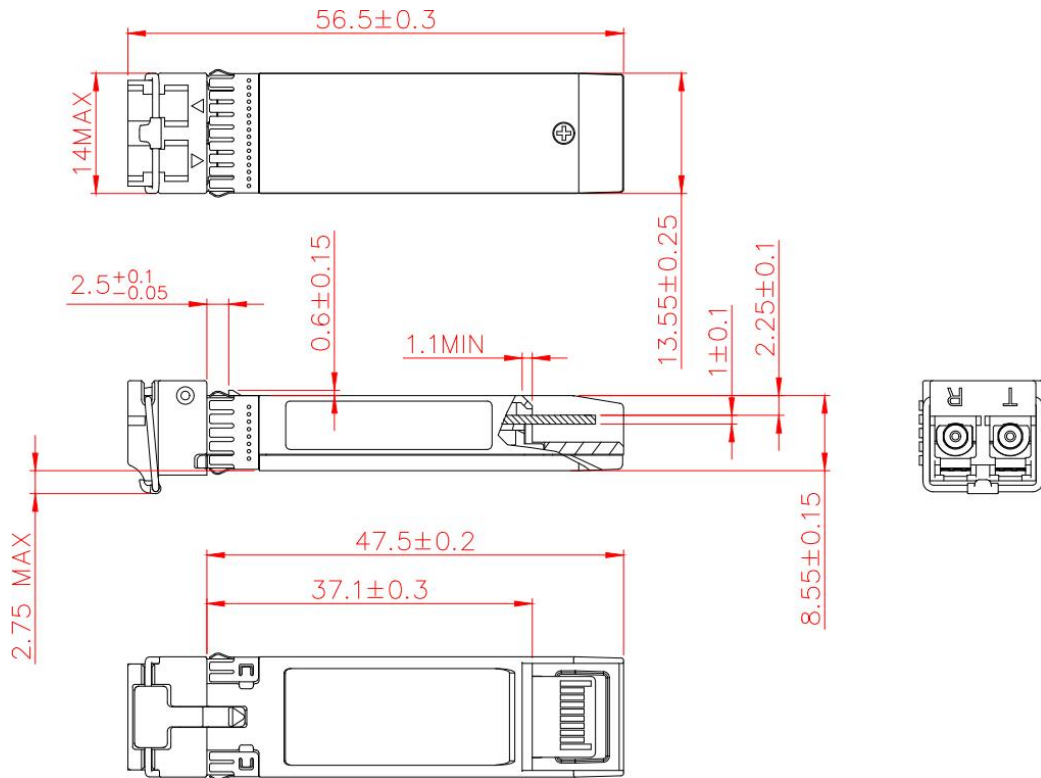

Figure 3. Module Mechanical Dimensions

Digital Diagnostics Functions

As defined by the SFF-8472, Our SFP28 transceivers provide digital diagnostic functions via a 2-wire serial interface, which allows real-time access to the following operating parameters:

- Transceiver temperature
- Laser bias current
- Transmitted optical power
- Received optical power
- Transceiver supply voltage

It also provides a sophisticated system of alarm and warning flags, which may be used to alert end-users when particular operating parameters are outside of a factory-set normal range. The operating and diagnostics information is monitored and reported by a Digital Diagnostics Transceiver Controller (DDTC) inside the transceiver, which is accessed



through the 2-wire serial interface. The memories are organized as a series of 8-bit data words that can be addressed individually or sequentially. The 2-wire serial interface provides sequential or random access to the 8 bit parameters, addressed from 0x00h to the maximum address of the memory. For more detailed information, including memory map definitions, please refer the SFF-8472 documentation.

Digital Diagnostic Monitor Accuracy

The following characteristics are defined over recommended operating conditions

Parameter	Accuracy	Unit
Internally measured transceiver temperature	+/-3	deg.C
Internally measured transceiver supply voltage	+/-3	%
Measured Tx bias current	+/-10	%
Measured Tx output power	+/-3	dB
Measured Rx received average optical power	+/-3	dB

Document Revision

Version No.	Date	Description
V1.0	2020-05-08	Initial released datasheet