



25G-SFP28-SR+

25Gbps SFP28 Transceiver, Multi Mode, 300m Reach

Product Features

- Supports up to 25.78Gbps bit rates
- Hot-pluggable SFP+ footprint
- 850nm VCSEL laser and PIN photodiode
- 300m over M5F MMF (50/125 um OM4)
- 200m over M5E MMF (50/125um OM3)
- Compliant with SFP+ MSA and SFF-8472 with duplex LC receptacle
- Compatible with RoHS
- Single +3.3V power supply
- Real Time Digital Diagnostic Monitoring
- Operating case temperature:
Standard: 0 to +70°C



Applications

- 25.78 Gb/s single lane 100GE SR4
- 25.78 Gb/s single lane 100GE eSR4 in the break out application

Description

The SFP28 transceivers are high performance, cost effective modules supporting data rate of 25.78Gbps over multimode fiber.

The transceiver consists of three sections: a VCSEL laser transmitter, a PIN photodiode integrated with a trans-impedance preamplifier (TIA) and MCU control unit. All modules satisfy class I laser safety requirements.

The transceivers are compatible with SFP Multi-Source Agreement and SFF-8472 digital diagnostics functions.

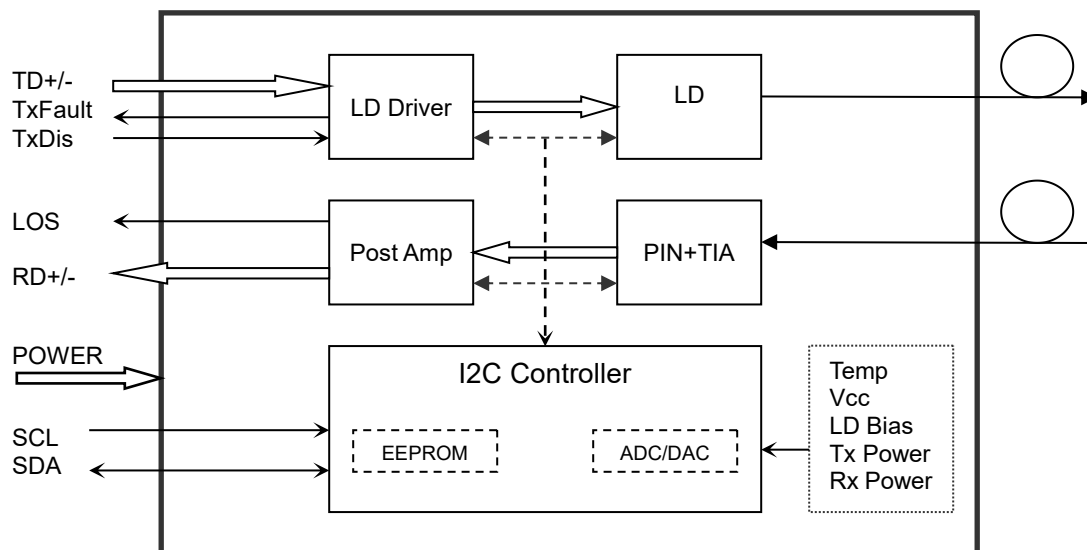

Transceiver functional diagram

Absolute Maximum Ratings

| Parameter | Symbol | Min | Max | Unit |
|---------------------|--------|------|-----|------|
| Supply Voltage | Vcc | -0.5 | 4 | V |
| Storage Temperature | Ts | -40 | +85 | °C |
| Operating Humidity | - | 5 | 85 | % |

Recommended Operating Conditions

| Parameter | Symbol | Min | Typical | Max | Unit |
|----------------------------|--------|-------|---------|-------|------|
| Operating Case Temperature | Tc | 0 | | +70 | °C |
| Power Supply Voltage | Vcc | 3.135 | 3.30 | 3.465 | V |
| Power Supply Current | Icc | | | 300 | mA |
| Data Rate | | 24.33 | | 25.78 | Gbps |



Optical and Electrical Characteristics

| Parameter | Symbol | Min | Typical | Max | Unit | Notes |
|--------------------------------|-----------------|------|---------|-------|----------|-------|
| Transmitter | | | | | | |
| Centre Wavelength | λ_c | 840 | 850 | 860 | nm | |
| Spectral Width (RMS) | $\Delta\lambda$ | | | 0.5 | nm | |
| Side-Mode Suppression Ratio | SMSR | - | - | - | dB | |
| Average Output Power | P_{out} | -8.4 | | 2.4 | dBm | 1 |
| Extinction Ratio | ER | 2.0 | | | dB | |
| Data Input Swing Differential | V_{IN} | 180 | | 950 | mV | 2 |
| Input Differential Impedance | Z_{IN} | 90 | 100 | 110 | Ω | |
| TX Disable | Disable | | 2.0 | | V_{cc} | V |
| | Enable | | 0 | | 0.8 | V |
| TX Fault | Fault | | 2.0 | | V_{cc} | V |
| | Normal | | 0 | | 0.8 | V |
| Receiver | | | | | | |
| Centre Wavelength | λ_c | 840 | 850 | 860 | nm | |
| Receiver Sensitivity | | | | -11.9 | dBm | 3,4 |
| Receiver Overload | | 2.4 | | | dBm | 3,4 |
| LOS De-Assert | LOS_D | | | -13 | dBm | |
| LOS Assert | LOS_A | -30 | | | dBm | |
| LOS Hysteresis | | 0.5 | | 4 | dB | |
| Data Output Swing Differential | V_{out} | 500 | | 900 | mV | 5 |
| LOS | High | | 2.0 | | V_{cc} | V |
| | Low | | | | 0.8 | V |

Notes:

- The optical power is launched into MMF.
- PECL input, internally AC-coupled and terminated.
- Measured with a PRBS 2³¹-1 test pattern @25.78Gbps, BER $\leq 5E-5$.
- Bits 110.3 and bits 118.3 control the locking modes of the internal retimer or CDR, default Value is "1".

| Bit 110.3 of A2h | Bit 118.3 of A2h | RX Data Rate | TX Data Rate | Status of RX CDR | Status of TX CDR |
|------------------|------------------|---------------|---------------|------------------|------------------|
| High/1 | High/1 | 24.33G/25.78G | 24.33G/25.78G | CDR select | CDR select |
| High/1 | Low/0 | 24.33G/25.78G | 9.95G/10.31G | CDR select | CDR bypass |
| Low/0 | High/1 | 9.95G/10.31G | 24.33G/25.78G | CDR bypass | CDR select |
| Low/0 | Low/0 | 9.95G/10.31G | 9.95G/10.31G | CDR bypass | CDR bypass |

- Internally AC-coupled.



Timing and Electrical

| Parameter | Symbol | Min | Typical | Max | Unit |
|---|----------------|-----|---------|-----------------|------|
| Tx Disable Negate Time | t_on | | | 2 | ms |
| Tx Disable Assert Time | t_off | | | 100 | μs |
| Time To Initialize, including Reset of Tx Fault | t_init | | | 300 | ms |
| Tx Fault Assert Time | t_fault | | | 100 | μs |
| Tx Disable To Reset | t_reset | 10 | | | μs |
| LOS Assert Time | t_loss_on | | | 100 | μs |
| LOS De-assert Time | t_loss_off | | | 100 | μs |
| Serial ID Clock Rate | f_serial_clock | | 100 | 400 | KHz |
| MOD_DEF (0:2)-High | V _H | 2 | | V _{cc} | V |
| MOD_DEF (0:2)-Low | V _L | | | 0.8 | V |

Diagnostics

| Parameter | Range | Unit | Accuracy | Calibration |
|--------------|---------------|------|----------|-------------|
| Temperature | 0 to +70 | °C | ±3°C | Internal |
| Voltage | 3.0 to 3.6 | V | ±3% | Internal |
| Bias Current | 0 to 15 | mA | ±10% | Internal |
| TX Power | -8.4.0 to 2.4 | dBm | ±3dB | Internal |
| RX Power | -12 to 2.4 | dBm | ±3dB | Internal |



Digital Diagnostic Memory Map

The transceivers provide serial ID memory contents and diagnostic information about the present operating conditions by the 2-wire serial interface (SCL, SDA).

The diagnostic information with internal calibration or external calibration all are implemented, including received power monitoring, transmitted power monitoring, bias current monitoring, supply voltage monitoring and temperature monitoring.

The digital diagnostic memory map specific data field defines as following.

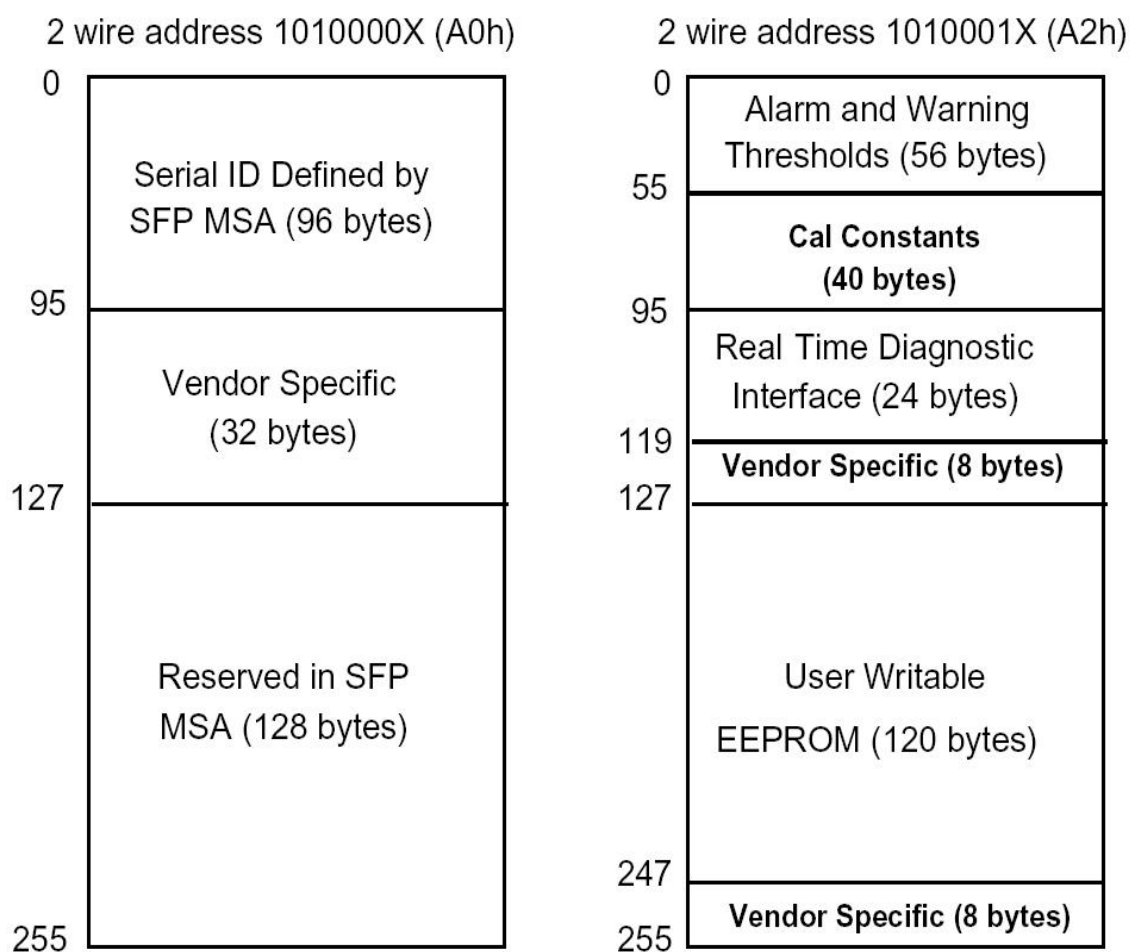

Pin Descriptions

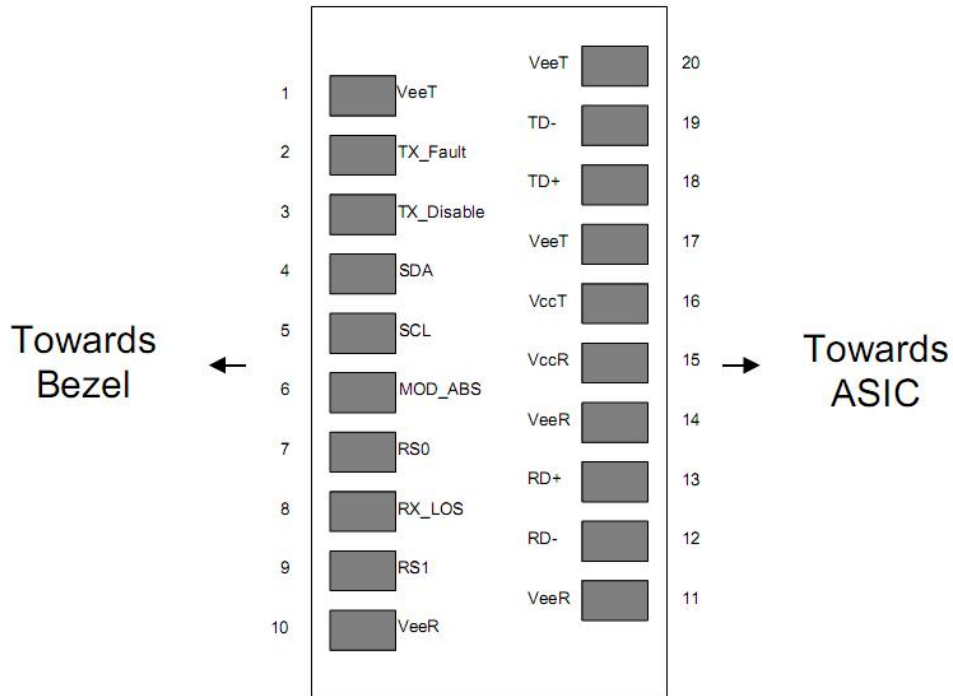

| Pin | Signal Name | Description | Plug Seq. | Notes |
|-----|------------------|---|-----------|--------|
| 1 | V _{EET} | Transmitter Ground | 1 | |
| 2 | TX FAULT | Transmitter Fault Indication | 3 | Note 1 |
| 3 | TX DISABLE | Transmitter Disable | 3 | Note 2 |
| 4 | SDA | SDA Serial Data Signal | 3 | |
| 5 | SCL | SCL Serial Clock Signal | 3 | |
| 6 | MOD_ABS | Module Absent. Grounded within the module | 3 | |
| 7 | RS0 | Not Connected | 3 | |
| 8 | LOS | Loss of Signal | 3 | Note 3 |
| 9 | RS1 | Not Connected | 3 | |
| 10 | V _{EER} | Receiver ground | 1 | |
| 11 | V _{EER} | Receiver ground | 1 | |
| 12 | RD- | Inv. Received Data Out | 3 | Note 4 |
| 13 | RD+ | Received Data Out | 3 | Note 4 |
| 14 | V _{EER} | Receiver ground | 1 | |
| 15 | V _{CCR} | Receiver Power Supply | 2 | |
| 16 | V _{CCT} | Transmitter Power Supply | 2 | |
| 17 | V _{EET} | Transmitter Ground | 1 | |

| | | | | |
|----|------------------|-----------------------|---|--------|
| 18 | TD+ | Transmit Data In | 3 | Note 5 |
| 19 | TD- | Inv. Transmit Data In | 3 | Note 5 |
| 20 | V _{EET} | Transmitter Ground | 1 | |

Notes:

Plug Seq.: Pin engagement sequence during hot plugging.

- 1) TX Fault is an open collector output, which should be pulled up with a 4.7k~10kΩ resistor on the host board to a voltage between 2.0V and V_{cc}+0.3V. Logic 0 indicates normal operation; Logic 1 indicates a laser fault of some kind. In the low state, the output will be pulled to less than 0.8V.
- 2) Laser output disabled on TDIS >2.0V or open, enabled on TDIS <0.8V.
- 3) LOS is open collector output. Should be pulled up with 4.7k~10kΩ on host board to a voltage between 2.0V and 3.6V. Logic 0 indicates normal operation; logic 1 indicates loss of signal.
- 4) RD-/+ : These are the differential receiver outputs. They are internally AC-coupled 100 differential lines which should be terminated with 100Ω (differential) at the user SERDES.
- 5) TD-/+ : These are the differential transmitter inputs. They are internally AC-coupled, differential lines with 100Ω differential termination inside the module.

Recommended Interface Circuit

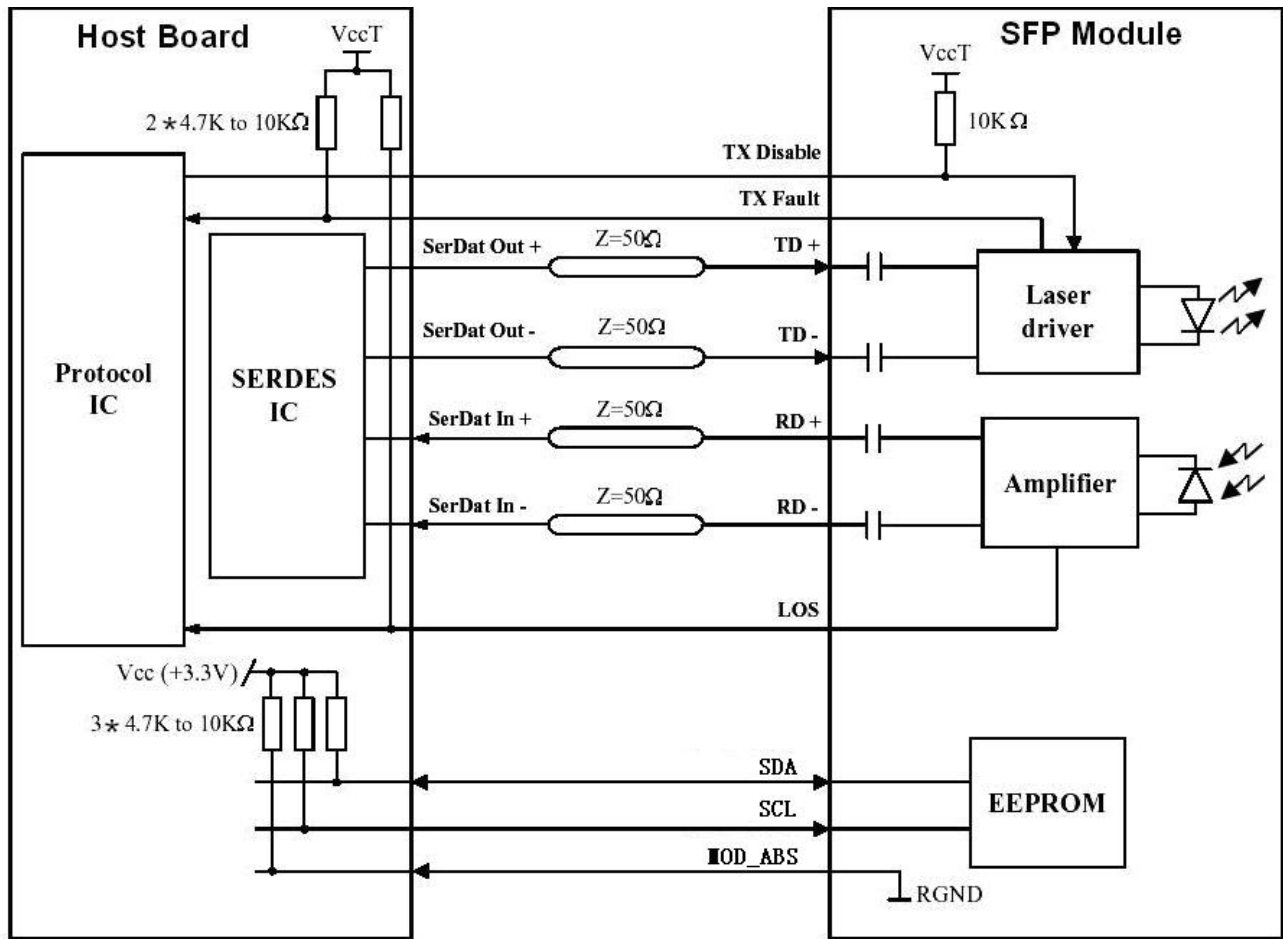

Mechanical Dimensions

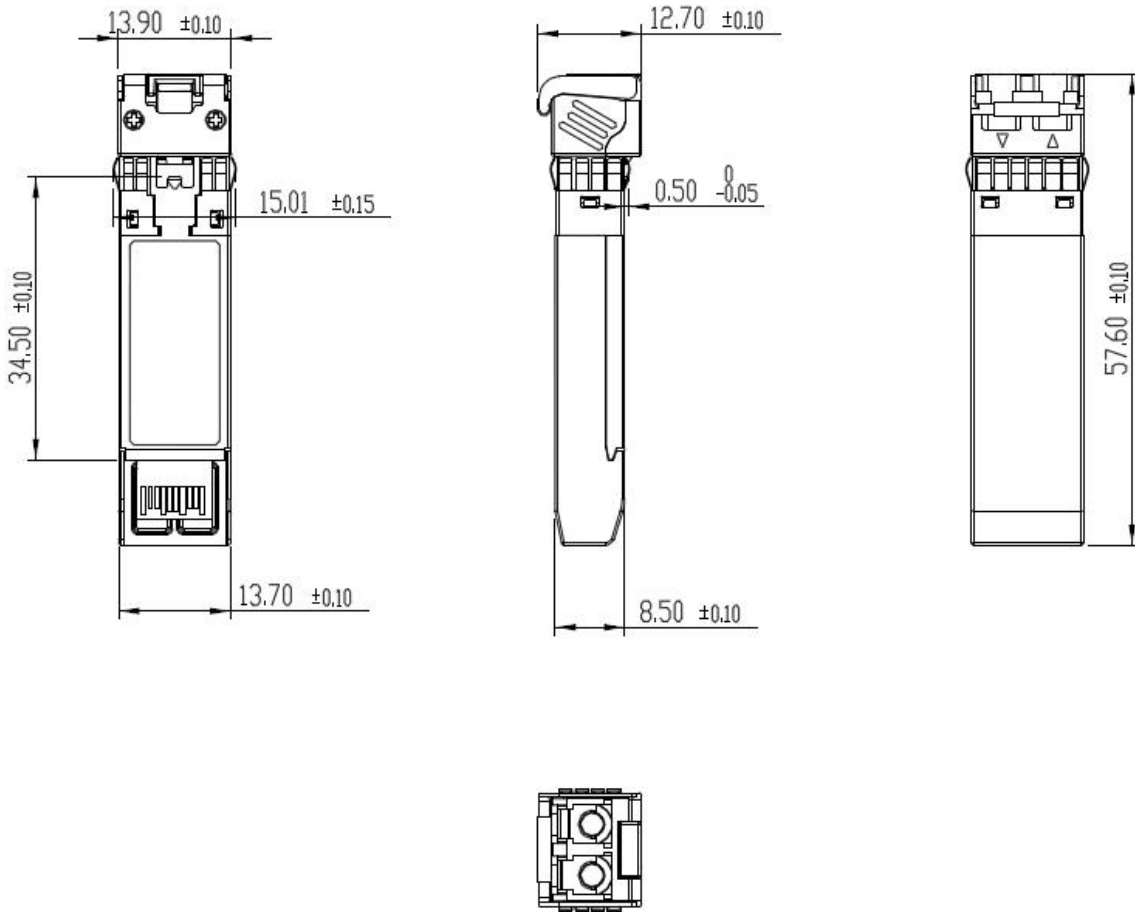

Ordering information

| Part Number | Product Description |
|---------------|--|
| 25G-SFP28-SR+ | 850nm, 25.78Gbps, LC, OM3-MMF 200m/OM4-MMF 300m, 0°C~+70°C |