



## 40G-QSFP-SR-BD

Bi-Directional, QSFP+ Pluggable, Duplex  
LC 40 Gigabit Ethernet Fiber-Optics  
Transceiver



## Data Sheet

### Description

The 40G-QSFP-SR-BD is a Four-Channel, Pluggable, LC Duplex, Fiber-Optic QSFP+ Transceiver for 40 Gigabit Ethernet Applications. This transceiver is a high performance module for short-range duplex data communication and interconnect applications. It integrates four electrical data lanes in each direction into transmission over a single LC duplex fiber optic cable. Each electrical lane operates at 10.3125 Gbps and conforms to the 40GE XLPPI interface.

The 40G-QSFP-SR-BD transceiver internally multiplexes an XLPPI 4x10G interface into two 20Gb/s electrical channels, transmitting and receiving each optically over one simplex LC fiber using bi-directional optics. This results in an aggregate bandwidth of 40Gbps into a duplex LC cable. This allows reuse of the installed LC duplex cabling infrastructure for 40GbE application.

Link distances up to 100 m using OM3 and 150m using OM4 optical fiber are supported. These modules are designed to operate over multimode fiber systems using a nominal wavelength of 850nm on one end and 900nm on the other end. The electrical interface uses a 38 contact QSFP+ type edge connector. The optical interface uses a conventional LC duplex connector. This module incorporates proven integrated circuit and VCSEL technology to provide reliable long life, high performance, and consistent service.

### Part Number Ordering Options

40 Gigabit Ethernet Transceiver	40G-QSFP-SR-BD-T
40 Gigabit Ethernet Receiver	40G-QSFP-SR-BD-R
Evaluation Kit*	40G-QSFP-SR-BD-EK

\*Includes GUI and User Guide

### Features

- Compliant to the 40GbE XLPPI electrical specification per IEEE 802.3ba-2010
- Compliant to QSFP+ SFF-8436 Specification
- Power Level 4: Max Power 3.5W
- Class 1M Eye Safety
- High port density: 21mm horizontal port pitch
- Operates at 10.3125 Gbps per electrical channel with 64b/66b encoded data
- Links up to 100m using OM3 and 150m using OM4 optical fiber  
+10 to +70°C case temperature operating range
- Proven High Reliability technology: VCSEL transmitters and PIN receiver
- Hot pluggable transceiver for ease of installation and servicing
- Two wire Serial (TWS) Management Interface with maskable interrupts for expanded functionality
- Utilizes a standard LC duplex fiber cable allowing reuse of existing cable infrastructure

### Applications

- 40 Gigabit Ethernet interconnects
- Datacom/Telecom switch & router connections
- Data aggregation and backplane applications
- Proprietary protocol and density applications

**WARNIG**

**INVISIBLE LASER RADIATION  
DO NOT VIEW DIRECTLY  
WITH OPTICAL INSTRUMENTS  
CLASS 1M LASER PRODUCT**

**CAUTION!** Viewing the laser output with certain optical instruments (for example, eye loupes, magnifiers and microscopes) within a distance of 100 mm may pose an eye hazard.

**CAUTION!** Use of controls or adjustments or performance of procedures other than those specified herein may result in hazardous radiation exposure.

Note: Standard used for classification: EN 60825-1:2007

**CLASS 1M LASER PRODUCT: INVISIBLE LASER RADIATION, DO NOT VIEW DIRECTLY WITH OPTICAL INSTRUMENTS**

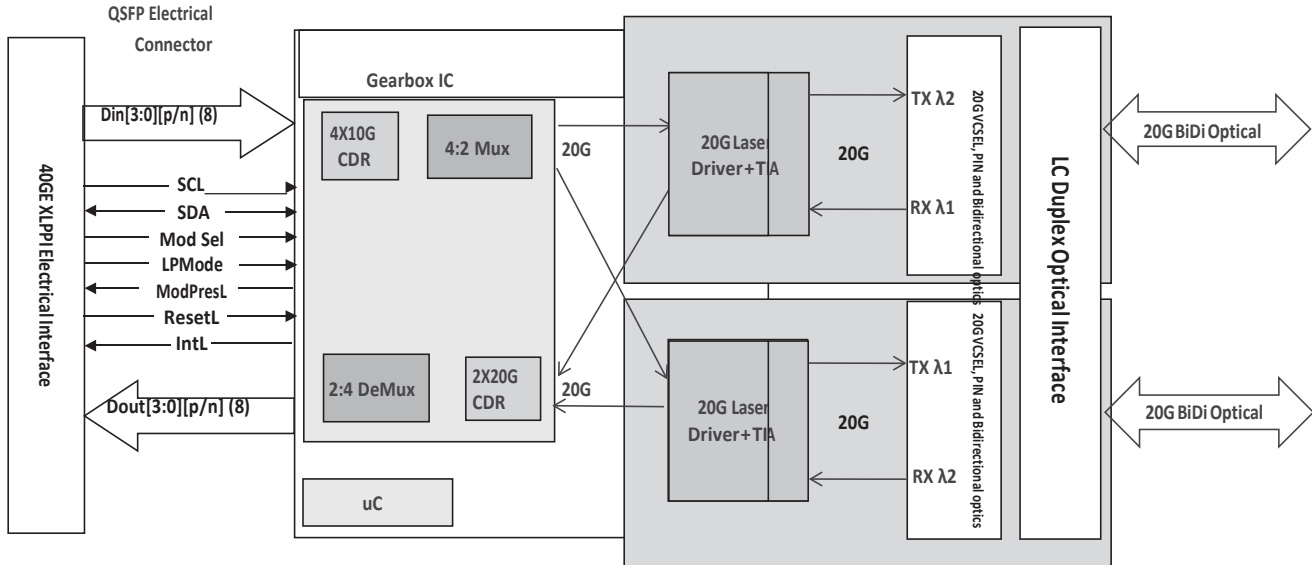

Figure 1. Transceiver Block Diagram

**Transmitter**

The optical transmitter portion of the transceiver (see Figure 1) incorporates a 4-channel XLPPi input buffer, electrical multiplexer, two laser drivers and two high speed VCSELs (Vertical Cavity Surface Emitting Laser). The transmitter is designed for EN 60825 and CDRH Class 1M eye safety compliance. The Tx Input Buffer provides XLPPi compatible differential inputs presenting a nominal differential input impedance of 100 Ohms. AC coupling capacitors are located inside the QSFP+ module and are not required on the host board. For module control and interrogation, the control interface (LVTTL compatible) incorporates a Two Wire Serial (TWS) interface of clock and data signals.

**Receiver**

The optical receiver portion of the transceiver (see Figure 1) incorporates two high speed PIN photodiodes, TIAs, signal processors, electrical de-multiplexer and 4 channel electrical output buffer blocks. The Rx Output Buffer provides XLPPi compatible differential outputs for the high speed electrical interface presenting nominal single-ended output impedances of 50 Ohms to AC ground and 100 Ohms differentially that should be differentially terminated with 100 Ohms. AC coupling capacitors are located inside the QSFP+ module and are not required on the host board.

The electrical output will squelch for loss of input signal (unless squelch is disabled) and channel de-activation through TWS interface. To reduce the need for polling, a hardware interrupt signal INTL is provided to inform hosts of an assertion of LOS or Tx\_FAULT.

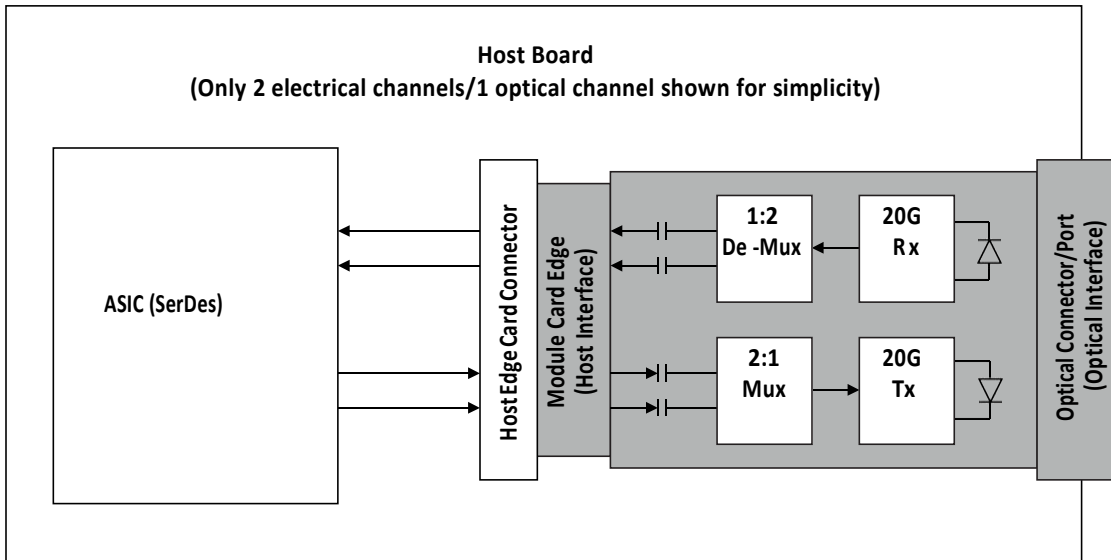

Figure 2. Application Reference Diagram

## High Speed Electrical Signal Interface

Figure 2 shows the interface between an ASIC/SerDes and the QSFP+ module. For simplicity, only two electrical channels and one optical channel is shown. The high speed signal lines are AC-coupled 100 Ohm differential lines. The AC coupling is inside the QSFP+ module and not required on the host board. The 100 Ohm differential terminations are inside the QSFP+ module for the transmitter lines and at the host ASIC/SerDes for the Receiver lines. All transmitter and receiver electrical channels are compliant to module XLPPi specifications per IEEE 802.3ba.

## Control Signal Interface

The module has the following low speed signals for control and status: ModSelL, LPMode, ResetL, ModPrsL, IntL. In addition, there is an industry standard two wire serial interface scaled for 3.3 volt LVTTTL. It is implemented as a slave device. Signal and timing characteristics are further defined in the Control Interface section. The registers of the serial interface memory are defined in the Memory Map section and the corresponding QSFP+ Memory Map document.

## Regulatory & Compliance Issues

Various standard and regulations apply to the modules. These include eye-safety, EMC, ESD and RoHS. See the Regulatory Section for details regarding these and component recognition. Please note the transmitter module is a Class 1M laser product – DO NOT VIEW RADIATION DIRECTLY WITH OPTICAL INSTRUMENTS. See Regulatory Compliance Table for details.

## Package Outline

The module is designed to meet the package outline defined in the QSFP+ SFF-8436 Specification. See the package outline and host board footprint figures (Figures 13 - 16) for details.

## Handling

The transceiver module can be damaged by exposure to current surges and over voltage events. Care should be taken to restrict exposure to the conditions defined in the Absolute Maximum Ratings. Wave soldering, reflow soldering and/or aqueous wash process with the modules on board are not recommended. Normal handling precautions for electrostatic discharge sensitive devices should be observed.

Each module is supplied with an inserted port plug for protection of the optical ports. This plug should always be in place whenever a fiber cable is not inserted.

The optical connector includes recessed elements that are exposed whenever a cable or port plug is not inserted. Prior to insertion of a fiber optic cable, it is recommended that the cable end be cleaned to avoid contamination from the cable plug. The port plug ensures the optics remains clean and no additional cleaning should be needed. In the event of contamination, standard LC port cleaning method may be used.

## Absolute Maximum Ratings

Stress in excess of any of the individual Absolute Maximum Ratings can cause immediate catastrophic damage to the module even if all other parameters are within Recommended Operating Conditions. It should not be assumed that limiting values of more than one parameter can be applied to the module concurrently. Exposure to any of the Absolute Maximum Ratings for extended periods can adversely affect reliability.

Parameter	Symbol	Min	Max	Units	Reference
Storage Temperature	T <sub>S</sub>	-40	85	°C	
3.3 V Power Supply Voltage	V <sub>CC</sub>	-0.5	3.6	V	
Data Input Voltage – Single Ended		-0.5	V <sub>CC</sub> +0.5	V	
Data Input Voltage – Differential	V <sub>dip</sub> - V <sub>din</sub>		1.0	V	
Control Input Voltage	V <sub>i</sub>	-0.5	V <sub>CC</sub> +0.5, 3.6	V	
Control Output Current	I <sub>O</sub>	-20	20	mA	
Relative Humidity	RH	5	95	%	

Note:

1. This is the maximum voltage that can be applied across the differential inputs without damaging the input circuitry.

## Recommended Operating Conditions

Recommended Operating Conditions specify parameters for which the optical and electrical characteristics hold unless otherwise noted. Optical and electrical characteristics are not defined for operation outside the Recommended Operating Conditions where reliability is not implied and damage to the module may occur for such operation over an extended period of time.

Parameter	Symbol	Min	Typ	Max	Units	Reference
Case Temperature	T <sub>C</sub>	+10		+70	°C	1
3.3 V Power Supply Voltage	V <sub>CC</sub>	3.1	3.3	3.47	V	
Signal Rate per Electrical Channel (4 x 10GBd)			10.3125		GBd	2
Signal Rate per Optical Channel (2 x 20GBd)			20.625		GBd	2
Control* Input Voltage High	V <sub>ih</sub>	2		V <sub>CC</sub> +.3	V	
Control* Input Voltage Low	V <sub>il</sub>	-0.3		0.8	V	
Two Wire Serial (TWS) Interface Clock Rate				400	kHz	
Power Supply Noise				50	mVpp	3
Receiver Differential Data Output Load			100			
Fiber Length for OM3		0.5		100	m	4
Fiber Length for OM4		0.5		150	m	4

\* Control signals, LVTTTL (3.3 V)

compatible Note:

1. The position of case temperature measurement is shown in Figure 8.
2. 64b/66b encoding is assumed.
3. Power Supply Noise is defined as the peak-to-peak noise amplitude over the frequency range at the host supply side of the recommended power supply filter with the module and recommended filter in place. Voltage levels including peak-to-peak noise are limited to the recommended operating range of the associated power supply. See Figure 9 for recommended power supply filter.
4. Connection and splice loss of 1.5dB is allocated. Modal Bandwidth for OM3 fiber: 2000 MHz.km for 850nm channel, 1400MHz.km for 900nm channel. Modal Bandwidth for OM4 fiber: 3700 MHz.km for 850nm channel, 1500MHz.km for 900nm channel.

### Transceiver Electrical Characteristics\*

The following characteristics are defined over the Recommended Operating Conditions unless otherwise noted. Typical values are for  $T_c = 40^\circ\text{C}$ ,  $V_{cc} = 3.3\text{ V}$

Parameter	Symbols	Min	Typ	Max	Units	Reference
Transceiver Power Consumption				3.5	W	
Transceiver Power Supply Current				1150	mA	
Transceiver Power On Initialization Time	$t_{\text{PWR INIT}}$			2000	ms	1

\* For control signal timing including ModSelL, LPMode, ResetL, ModPrsL, IntL, SCL and SDA see Control Interface Section. Note:

1. Power On Initialization Time is the time from when the supply voltages reach and remain above the minimum Recommended Operating Conditions to the time when the module enables TWS access. The module at that point is fully functional.

### Transmitter Electrical Characteristics

The following characteristics are defined over the Recommended Operating Conditions unless otherwise noted. Typical values are for  $T_c = 40^\circ\text{C}$ ,  $V_{cc} = 3.3\text{ V}$

Parameter	Symbol	Min	Typ	Max	Units	Notes
LOS Assert Threshold: Tx Data Input Differential Peak-to-Peak Voltage Swing	$\Delta V_{di\text{ pp los}}$	40	80	190	mVpp	
LOS Hysteresis		0.5		4	dB	1

Parameter (From Table 86A-2 of IEEE 802.3ba)	Test Point*	Min	Typ	Max	Units	Notes/Conditions
Single ended input voltage tolerance [2]	TP1a	-0.3		4	V	Referred to TP1 signal common
AC common mode input voltage tolerance	TP1a	15			mV	RMS
Differential input return loss	TP1	See IEEE 802.3ba 86A.4.1.1			dB	10 MHz to 11.1 GHz
Differential to common-mode input return loss	TP1	10			dB	10 MHz to 11.1 GHz
J2 Jitter tolerance	TP1a	0.17			UI	Defined in IEEE 802.3ba spec
J9 Jitter tolerance	TP1a	0.29			UI	Defined in IEEE 802.3ba spec
Data Dependent Pulse Width Shrinkage (DDPWS) tolerance	TP1a	0.07			UI	
Eye Mask Coordinates: X1, X2 Y1, Y2	TP1a	SPECIFICATION VALUES 0.11, 0.31 95, 350			UI mV	Hit Ratio = $5 \times 10^{-5}$

\* See Figure 6 for Test Point definitions.

Note:

1. LOS Hysteresis is defined as  $20 \cdot \log(\text{LOS De-assert Level} / \text{LOS Assert Level})$ .
2. The single ended input voltage tolerance is the allowable range of the instantaneous input signals.

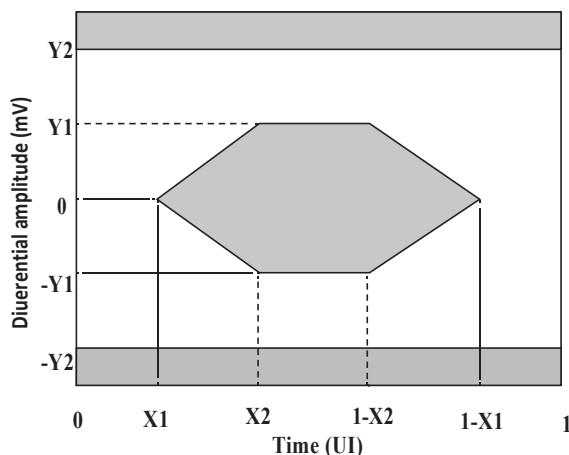

Figure 3. Tx Electrical Eye Mask Coordinates at Hit ratio  $5 \times 10^{-5}$  hits per sample

## Receiver Electrical Characteristics

The following characteristics are defined over the Recommended Operating Conditions unless otherwise noted. Typical values are for  $T_c = 40^\circ\text{C}$ ,  $V_{cc} = 3.3\text{ V}$

Parameter	Test Point*	Min	Typ	Max	Units	Notes/Conditions
Single ended output voltage tolerance	TP4	-0.3		4	V	Referred to signal common
AC common mode voltage (RMS)	TP4			7.5	mV	RMS
Termination mismatch at 1MHz	TP4			5	%	
Differential output return loss	TP4	See IEEE 802.3ba 86A.4.2.1			dB	10 MHz to 11.1 GHz
Common-mode output return loss	TP4	See IEEE 802.3ba 86A.4.1.2			dB	10 MHz to 11.1 GHz
Output transition time 20% to 80%	TP4	28			ps	
J2 Jitter output	TP4			0.41	UI	
J9 Jitter output	TP4			0.62	UI	
Eye Mask coordinates: X1, X2 Y1, Y2	TP4	SPECIFICATION VALUES 0.29, 0.5 150, 425			UI mV	Hit Ratio = $5 \times 10^{-5}$

\* See Figure 6 for Test Point definitions.

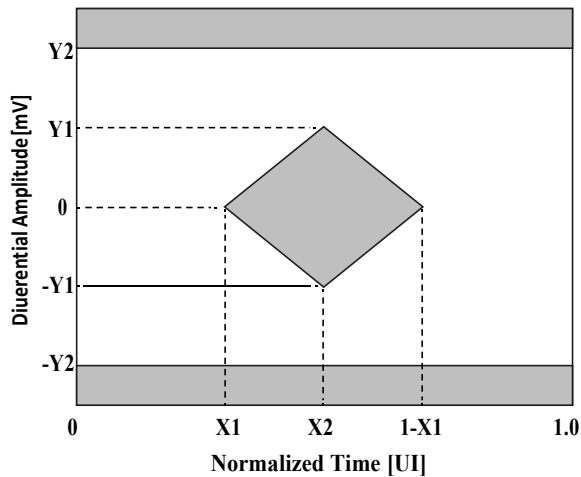

Figure 4. Rx Electrical Eye Mask Coordinates (TP4) at Hit ratio  $5 \times 10^{-5}$  hits per sample

## Transmitter Optical Characteristics

The following characteristics are defined over the Recommended Operating Conditions unless otherwise noted. Typical values are for  $T_c = 40^\circ\text{C}$ ,  $V_{cc} = 3.3\text{ V}$

Parameter	Test Point*	Min	Typ	Max	Units	Notes/Conditions
Center wavelength 1	TP2	832	850	868	nm	
Center wavelength 2	TP2	882	900	918	nm	
RMS spectral width	TP2			0.59	nm	RMS Spectral Width is the standard deviation of the spectrum
Average launch power, 850nm lane	TP2	-4.0	0	5	dBm	Max: Set by the lower of Class 1M or Rx overload
Average launch power, 900nm lane	TP2	-4.0	0	5	dBm	Max: Set by the lower of Class 1M or Rx overload
Optical Modulation Amplitude (OMA) 850nm lane	TP2	-1.0	0	5	dBm	
Optical Modulation Amplitude (OMA) 900nm lane	TP2	-1.0	0	5	dBm	
Peak power, each lane	TP2			7	dBm	

Extinction ratio, each lane	TP2	3	4.5	dB
RIN12OMA	TP2		-130	dB/Hz
Optical rise and fall time, 20-80%	TP2		21	ps
Optical return loss tolerance	TP2		12	dB
Encircled flux	TP2	$\geq 86\%$ at 19 $\mu\text{m}$ , $\leq 30\%$ at 4.5 $\mu\text{m}$		If measured into type A1a.2 50 $\mu\text{m}$ fiber in accordance with EN 61280-1-4
20.625 Gb/s Eye Mask: X1, X2, X3, Y1, Y2, Y3	TP2	SPECIFICATION VALUES 0.23, 0.34, 0.43, 0.27, 0.35, 0.40		Scaled IEEE 802.3ba 40GBASE-SR4 TX mask; Hit Ratio = $5 \times 10^{-5}$
Average launch power of OFF trans- mitter, each lane	TP2		-30	dBm

\* See Figure 6 for Test Point definitions.

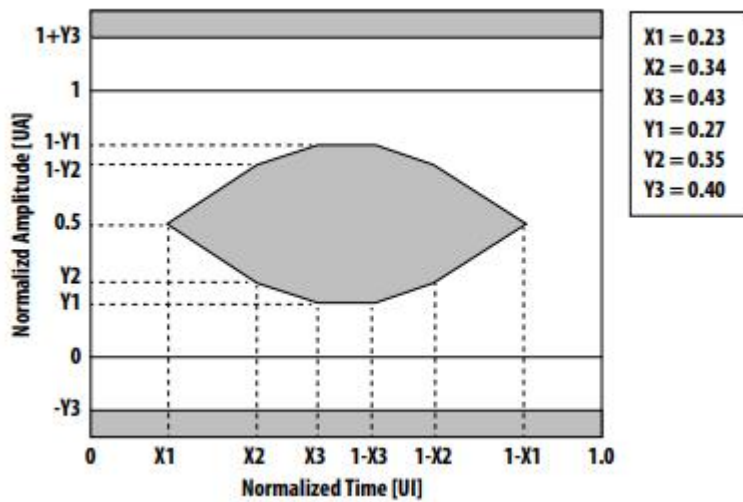

Figure 5. Transmitter Optical Eye Mask definitions at Hit Ratio  $5 \times 10^{-5}$  hits per sample

## Receiver Optical Characteristics

The following characteristics are defined over the Recommended Operating Conditions unless otherwise noted. Typical values are for  $T_c = 40^\circ\text{C}$ ,  $V_{cc} = 3.3\text{ V}$

Parameter	Test Point*	Min	Typ	Max	Units	Notes/Conditions
Center wavelength 1	TP3		850		nm	
Center wavelength 2	TP3		900		nm	
Damage Threshold [1]	TP3	+7.0			dBm	
Maximum Average power at receiver input, each lane (overload)	TP3			+5.0	dBm	
Transceiver Reflectance	TP3			-15	dB	
Peak power, each lane	TP3			7	dBm	
Optical Modulation Amplitude (OMA), 850nm lane (unstressed sensitivity)	TP3			-7.1	dBm	BER = 1e-12
Optical Modulation Amplitude (OMA), 900nm lane (unstressed sensitivity)	TP3			-7.7	dBm	BER = 1e-12
Stressed receiver sensitivity in OMA, 850nm lane	TP3		-4.5	-3.83	dBm	BER = 1e-12
Stressed receiver sensitivity in OMA, 900nm lane	TP3		-4.5	-3.86	dBm	BER = 1e-12
Conditions of stressed receiver sensitivity: [2]	TP3					
Vertical Eye Closure Penalty, 850nm	TP3			2.4	dB	
Vertical Eye Closure Penalty, 900nm	TP3			3.1	dB	
Stressed eye Jitter, each lane	TP3		0.13		UI	
LOS Assert	TP3	-30		-9.1	dBm	
LOS De-Assert (850nm)	TP3			-8.6	dBm	
LOS De-Assert (900nm)	TP3			-8.6	dBm	
LOS Hysteresis	TP3	0.5			dB	

\* See Figure 6 for Test Point definitions.

Notes:

1. The receiver shall be able to tolerate, without damage, continuous exposure to a modulated optical input signal having this power level on one lane. The receiver does not have to operate correctly at this input power.
2. Vertical eye closure penalty and stressed eye jitter are test conditions for measuring stressed receiver sensitivity. They are not characteristics of the receiver.

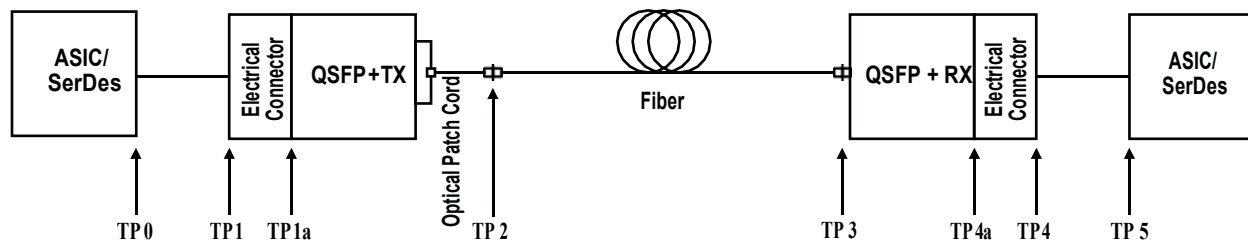

TP0: Host ASIC transmitter output at ASIC package contact on the Host board

TP1: Host ASIC transmitter output across the Host Board at the input side of the Host QSFP+ electrical connector

TP2: QSFP+ transmitter LC Duplex optical output at the end of a 2m to 5m patch cord

TP3: QSFP+ receiver LC Duplex optical input at the end of the fiber

TP4a: QSFP+ receiver electrical output at the input side of the Host QSFP+ electrical connector

TP4: QSFP+ receiver electrical output at the output side of the Host QSFP+ electrical connector

TP5: Host ASIC receiver input at ASIC package contact on the Host board

Figure 6. Test point definitions



### Regulatory Compliance Table

Feature	Test Method	Performance
Electrostatic Discharge (ESD) to the Electrical Contacts	JEDEC Human Body Model (HBM) (JESD22-A114-B)	Transceiver module withstands 1kV on high speed pins and 2kV on low speed pins
Electrostatic Discharge (ESD) to Optical connector	GR1089	10 discharges of 8 kV on the electrical face-plate with device inserted into a panel
Electrostatic Discharge (ESD) to Optical connector	Variation of EN 61000-4-2	Air discharge of 15kV(min) to connector w/o damage
Electromagnetic Interference (EMI)	FCC Part 15 CENELEC EN55022 (CISPR 22A) VCCI Class 1	Typically passes with 10 dB margin. Actual performance dependent on enclosure design
Immunity	Variation of EN 61000-4-3	Typically minimum effect from a 10V/m field swept from 80 MHz to 1 GHz applied to the module without a chassis enclosure
Laser Eye Safety and Equipment Type Testing	IEC standard (EN 60825-1:2007 and EN 60825-2:2004+A1+A2:2010) CFR 21 Section 1040	Pout: EN AEL & US FDA CDRH Class 1M
Component Recognition	Underwriters Laboratories and Canadian Standards Association Joint Component Recognition for Information Technology Equipment including Electrical Business Equipment	UL File Number: E173874, Vol. 1
RoHS Compliance	BS EN 1122:2001 Mtd B by ICP for Cadmium, EPA Method 3051A by ICP for Lead and Mercury, EPA Method 3060A & 7196A by UV/Vis Spectrophotometry for Hexavalent Chromium. EPA Method 3540C/3550B by GC/MS for PPB and PBDE  BS EN method by ICP and EPA methods by ICP, UV/Vis Spectrophotometry and GC/MS.	Less than 100 ppm of cadmium, Less than 1000 ppm of lead, mercury, hexavalent chromium, polybrominated biphenyls, and polybrominated biphenylesters.

### QSFP+ Transceiver Pad Layout

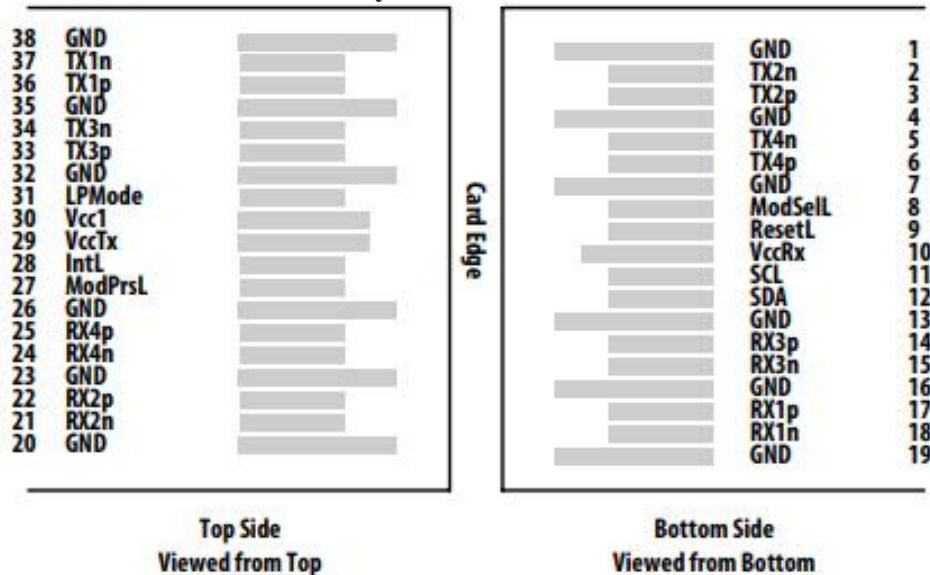

Figure 7. QSFP+ Transceiver Pad Layout

## Pins

Pin	Logic	Symbol	Description	Plug Sequence	Notes
1		GND	Ground	1	1
2	CML-I	Tx2n	Transmitter Inverted Data Input	3	
3	CML-I	Tx2p	Transmitter Non-Inverted Data Input	3	
4		GND	Ground	1	1
5	CML-I	Tx4n	Transmitter Inverted Data Input	3	
6	CML-I	Tx4p	Transmitter Non-Inverted Data Input	3	
7		GND	Ground	1	1
8	LVTTL-I	ModSelL	Module Select	3	
9	LVTTL-I	ResetL	Module Reset	3	
10		Vcc Rx	+3.3V Power supply receiver	2	2
11	LVC MOS-I/O	SCL	2-wire serial interface clock	3	
12	LVC MOS-I/O	SDA	2-wire serial interface data	3	
13		GND	Ground	1	1
14	CML-O	Rx3p	Receiver Non-Inverted Data Output	3	
15	CML-O	Rx3n	Receiver Inverted Data Output	3	
16		GND	Ground	1	1
17	CML-O	Rx1p	Receiver Non-Inverted Data Output	3	
18	CML-O	Rx1n	Receiver Inverted Data Output	3	
19		GND	Ground	1	1
20		GND	Ground	1	1
21	CML-O	Rx2n	Receiver Inverted Data Output	3	
22	CML-O	Rx2p	Receiver Non-Inverted Data Output	3	
23		GND	Ground	1	1
24	CML-O	Rx4n	Receiver Inverted Data Output	3	
25	CML-O	Rx4p	Receiver Non-Inverted Data Output	3	
26		GND	Ground	1	1
27	LVTTL-O	ModPrsL	Module Present	3	
28	LVTTL-O	IntL	Interrupt	3	
29		Vcc Tx	+3.3V Power supply transmitter	2	2
30		Vcc1	+3.3V Power Supply	2	2
31	LVTTL-I	LPMODE	Low Power Mode	3	
32		GND	Ground	1	1
33	CML-I	Tx3p	Transmitter Non-Inverted Data Input	3	
34	CML-I	Tx3n	Transmitter Inverted Data Input	3	
35		GND	Ground	1	1
36	CML-I	Tx1p	Transmitter Non-Inverted Data Input	3	
37	CML-I	Tx1n	Transmitter Inverted Data Input	3	
38		GND	Ground	1	1

### Note

1. GND is the symbol for signal supply (power) common for the QSFP+ module. All are common within the QSFP+ module and all module voltages are referenced to this potential unless otherwise noted. Connect these directly to the host board signal-common ground plane
2. Vcc Rx, Vcc1 and Vcc Tx are the receiver and transmitter power supplies and shall be applied concurrently.

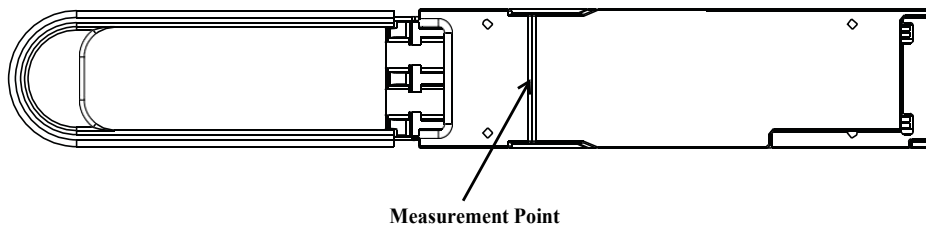

Figure 8. Case Temperature Measurement Point

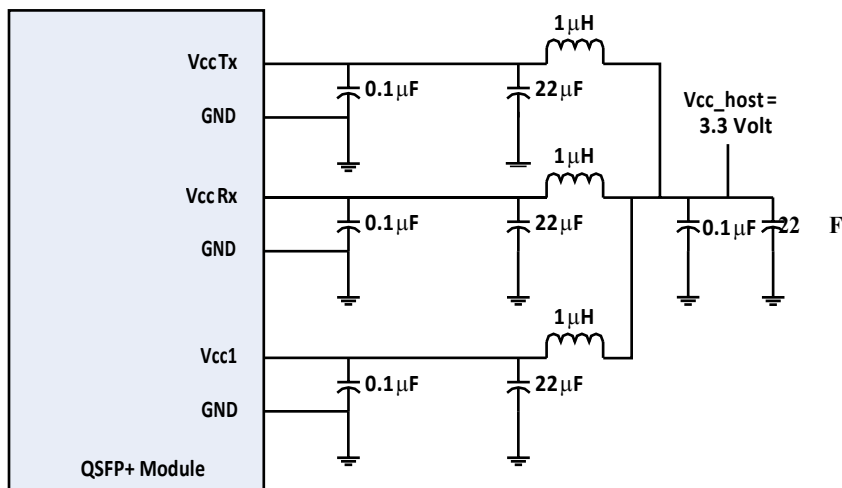

Figure 9. Recommended Power Supply Filter

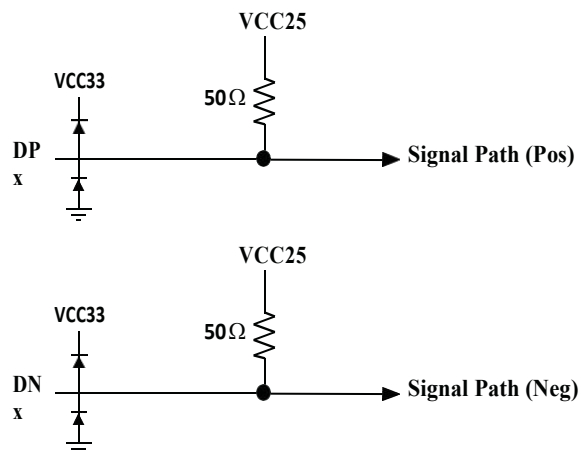

Figure 10. Transmitter Data Input Equivalent Circuit

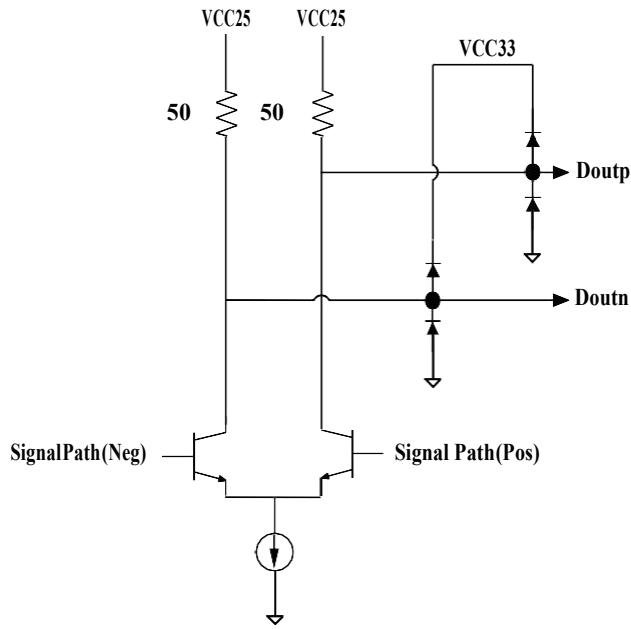

Figure 11. Receiver Data Output Equivalent Circuit

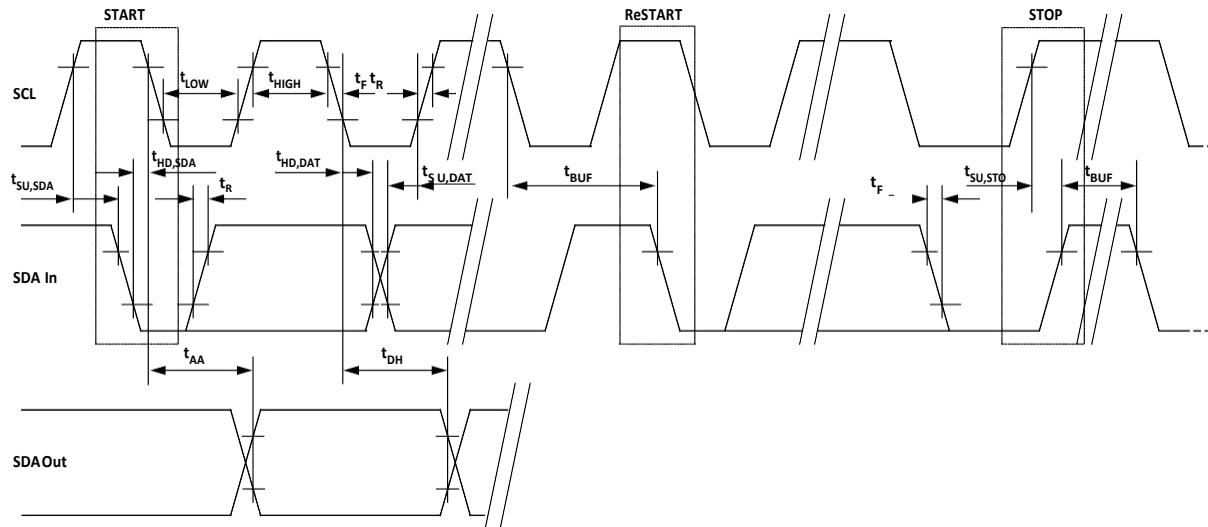
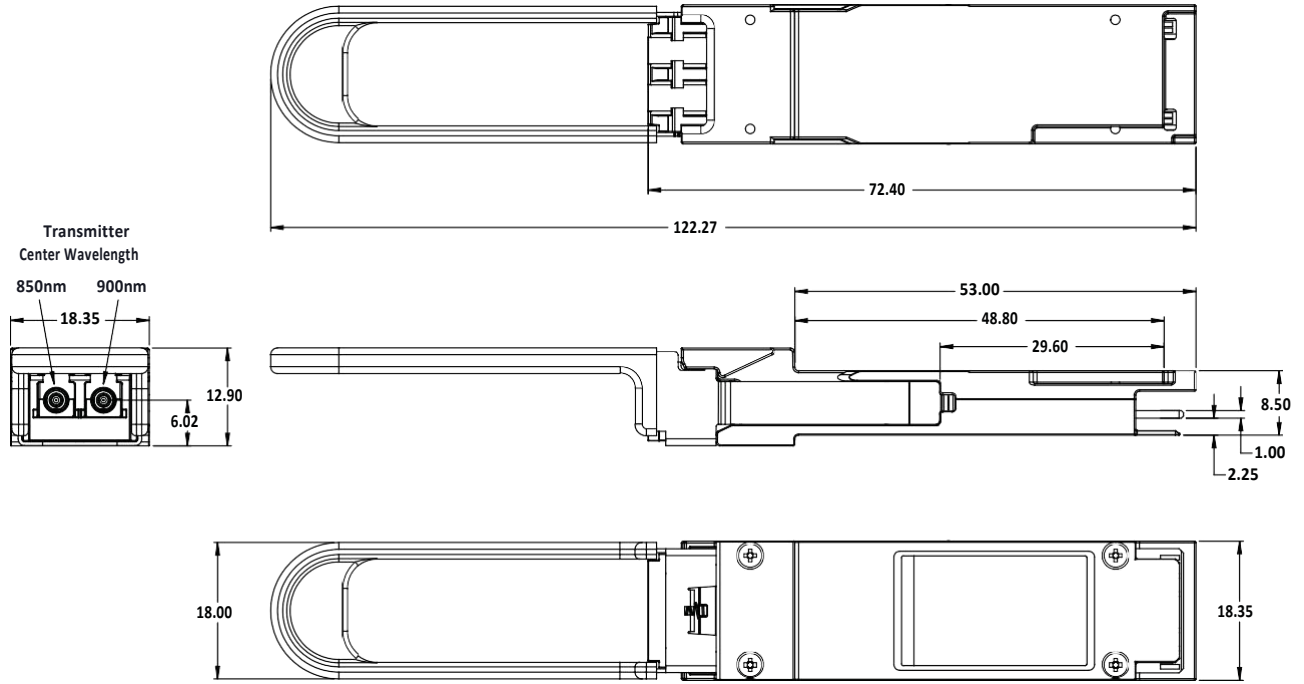

Figure 12. TWS Interface Bus Timing

### Package Outline, Host PCB Footprint and Bezel Design



All dimensions in mm

**Figure 13. Mechanical Package Outline**



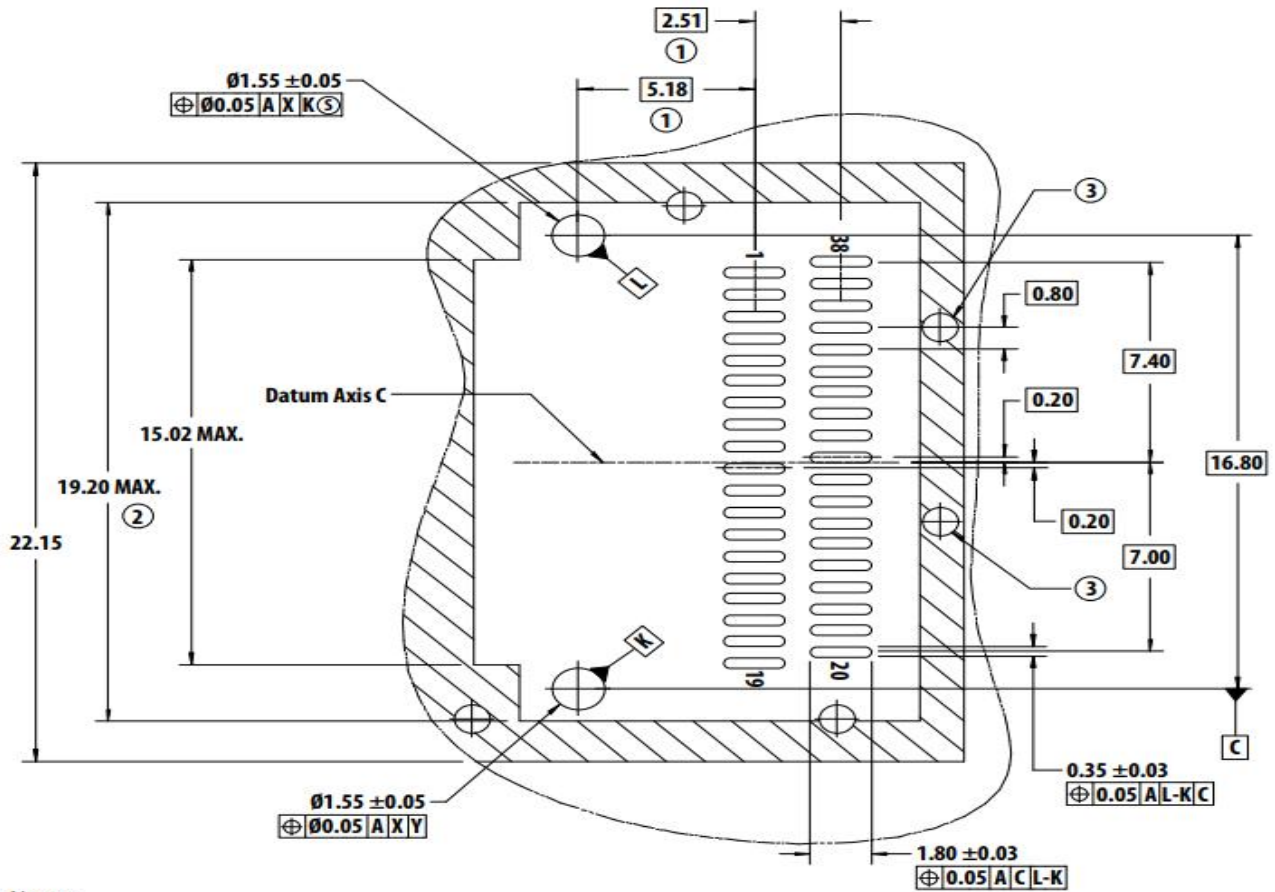

- Notes:
1. Centerline of Pad
  2. Surface traces permitted within this length
  3. Indicated holes are optional

All dimensions in mm

Figure 15. QSFP+ Host Board Mechanical Footprint Detail

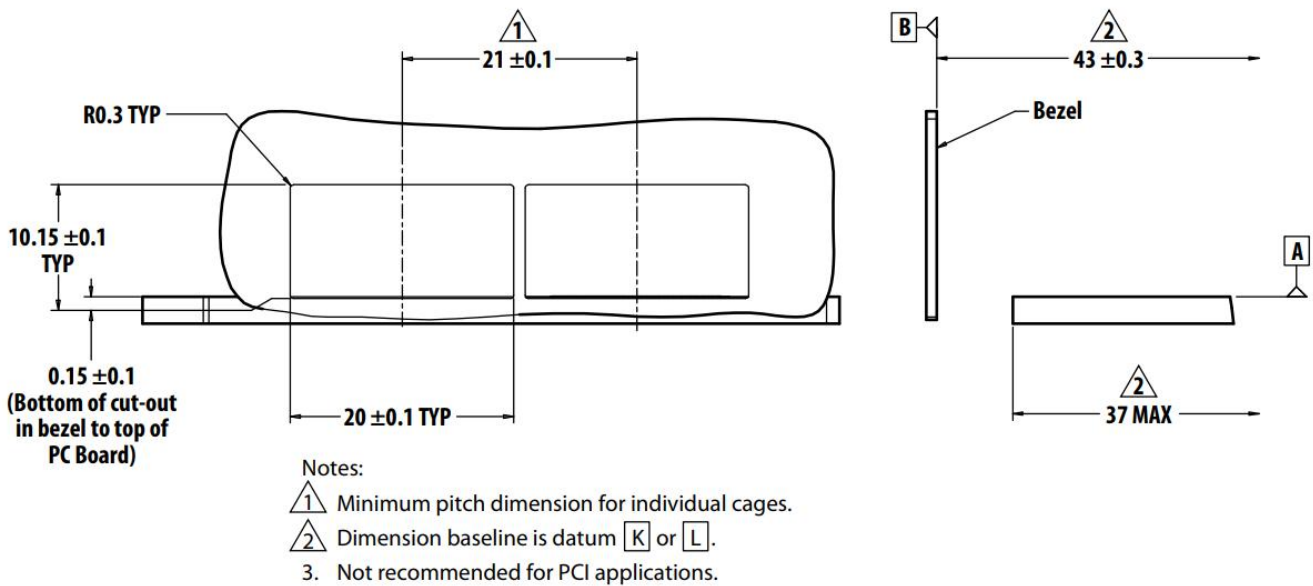

- Notes:
1. Minimum pitch dimension for individual cages.
  2. Dimension baseline is datum **K** or **L**.
  3. Not recommended for PCI applications.

All dimensions in mm

Figure 16. Host Board Bezel Design



## Control Interface

The control interface combines dedicated signal lines for ModSelL, LP Mode, ResetL, ModPrsL, IntL with two-wire serial (TWS), interface clock (SCL) and data (SDA), signals to provide users rich functionality over an efficient and easily used interface. The TWS interface is implemented as a slave device and compatible with industry standard two-wire serial protocol. It is scaled for 3.3 volt LVTTTL. Outputs are high-z in the high state to support busing of these signals. Signal and timing characteristics are further defined in the Control I/O Characteristics section.

## ModSelL

The ModSelL is an input signal. When held low by the host, the module responds to 2-wire serial communication commands. The ModSelL allows the use of multiple QSFP+ modules on a single 2-wire interface bus. When the ModSelL is “High”, the module will not respond to or acknowledge any 2-wire interface communication from the host. ModSelL signal input node is biased to the “High” state in the module. In order to avoid conflicts, the host system shall not attempt 2-wire interface communications within the ModSelL deassert time after any QSFP+ modules are deselected. Similarly, the host must wait at least for the period of the ModSelL assert time before communicating with the newly selected module. The assertion and de-asserting periods of different modules may overlap as long as the above timing requirements are met.

## ResetL

The ResetL signal is pulled to Vcc in the QSFP+ module. A low level on the ResetL signal for longer than the minimum pulse length ( $t_{Reset\_init}$ ) initiates a complete module reset, returning all user module settings to their default state. Module Reset Assert Time ( $t_{init}$ ) starts on the rising edge after the low level on the ResetL pin is released. During the execution of a reset ( $t_{init}$ ) the host shall disregard all status bits until the module indicates a completion of the reset interrupt. The module indicates this by posting an IntL signal with the Data\_Not\_Ready bit negated. Note that on power up (including hot insertion) the module will post this completion of reset interrupt without requiring a reset.

## LPMode

Low power mode. When held high by host, the module is held at low power mode with power consumption meeting class 1 power level (1.5W). Under low power mode, high speed operation is not functional and all high speed indicators are not reliable while the TWS management interface is functional. When held low by host, the module operates in the normal mode.

## ModPrsL

ModPrsL is pulled up to Vcc\_Host on the host board and grounded in the module. The ModPrsL is asserted “Low” when inserted and de-asserted “High” when the module is physically absent from the host connector.

## IntL

IntL is an output signal. When “Low”, it indicates a possible module operational fault or a status critical to the host system. The host identifies the source of the interrupt using the 2-wire serial interface. The IntL signal is an open collector output and must be pulled to host supply voltage on the host board. A corresponding soft status IntL signal is also available in the transceiver memory page 0 address 2 bit 1.

## Soft Status and Control

A number of soft status signals and controls are available in the 40G-QSFP-SR-BD transceiver memory and accessible through the TWS interface. Soft status signals include receiver LOS, transmitter LOS, and a transmitter fault. Some soft controls include transmitter disable (Tx\_Dis), receiver output disable (Rx\_Dis), transmitter squelch disable (Tx\_SqDis), receiver squelch disable (Rx\_SqDis) and masking of status signal in triggering IntL. All soft control entries are volatile.

## Receiver LOS

The Receiver LOS status signal is on page 0 address 3 bits 0-3. Receiver LOS is based on received optical power modulation amplitude (OMA). The status register is latched and it is cleared on read. The first 20G lane RX is mapped to the first 2 RX lanes as defined in QSFP, and the second 20G RX lane is mapped to the third and fourth RX lanes as defined in QSFP MSA.

## Transmitter LOS

The transmitter LOS status signal is on page 0 address 3 bits 4-7. Transmitter LOS is based on input differential voltage. The status register is latched and it is cleared on read.

## Transmitter Fault

Transmitter fault status is reported in page0 register 4. Transmitter fault will be asserted when the laser cannot be controlled anymore, or it could cause harm to eyes as defined by the eyesafety regulation. The status is latched and cleared on read.

## Transmitter Disable

The transmitter Disable control is on page 0 address register 86. Because 2 10G input lanes are muxed into one 20G TX optical lane, either one of these lanes getting disabled will disable the 20G optical signal.

## Receiver Disable

The received disable control is on page 3 address 241 bits 4-7. Asserting any bit would cause the corresponding lane’s RX output to be disabled.

## Transmitter Squelch Disable

The Transmitter squelch disable control is on page 3 address 240 bits 0-3. 40G-QSFP-SR-BD transceivers have transmitter squelch enabled as default.

## Receiver Squelch Disable

The receiver squelch disable control is on page 3 address 240 bits 4-7. 40G-QSFP-SR-BD transceivers have receiver output squelch enabled as default.



## I/O Timing for Control and Status Functions

The following characteristics are defined over the Recommended Operating Conditions unless otherwise noted.

Parameter	Symbol	Min	Max	Units	Reference
Initialization Time	t_init		2000	ms	Time from power on, hot plug or rising edge of Reset until the module is fully functional. This time does not apply to non Power level 0 modules in the Low Power state
LPMODE Assert Time	ton_LPMODE		100	μs	Time from assertion of LPMODE until the module power consumption enters power level 1
Interrupt Assert Time	ton_IntL		200	ms	Time from occurrence of condition triggering IntL until Vout:IntL=V <sub>ol</sub>
Interrupt De-assert Time	toff_IntL		500	μs	Time from clear on read operation of associated flag until Vout:IntL=V <sub>oh</sub> . This includes deassert times for RX LOS, TX Fault and other flag bits
Reset Init Assert Time	t_reset_init		2	μs	A Reset is generated by a low level longer than the minimum reset pulse time present on the ResetL pin
Reset Assert Time	t_reset		2000	ms	Time from rising edge on the ResetL pin until the module is fully functional
Serial Bus Hardware Ready Time	t_serial		2000	ms	Time from power on until module responds to data transmission over the 2-wire serial bus
Monitor Data Ready Time	t_data		2000	ms	Time from power on to data not ready, bit 0 of Byte 2, deasserted and IntL asserted
RX LOS Assert Time	ton_los		100	ms	Time from RX LOS state to RX LOS bit set and IntL asserted
TX Fault Assert Time	ton_Txfault		200	ms	Time from TX Fault state to TX fault bit set and IntL asserted
Flag Assert Time	ton_Flag		200	ms	Time from occurrence of condition triggering flag to associated flag bit set and IntL asserted.
Mask Assert Time	ton_Mask		100	ms	Time from mask bit set until associated IntL assertion is inhibited
Mask Deassert Time	toff_Mask		100	ms	Time from mask bit cleared until associated IntL operation resumes
Power Set Assert Time	ton_Pdown		100	ms	Time from P_Down bit set until module power consumption enters power level 1
Power Set Deassert Time	toff_Pdown		300	ms	Time from P_Down bit cleared until the module is fully functional
RX Squelch Assert Time	ton_Rxsq		80	μs	Time from loss of RX input signal until the squelched output condition is reached
RX Squelch Deassert Time	toff_Rxsq		1	ms	Time from resumption of RX input signals until normal RX output condition is reached
TX Squelch Assert Time	ton_Txsq		400	ms	Time from loss of TX input signal until the squelched output condition is reached
TX Squelch Deassert Time	toff_Txsq		400	ms	Time from resumption of TX input signals until nominal TX output condition is reached
TX Disable Assert Time	ton_txdis		100	ms	Time from TX Disable bit set until optical output falls below 10% of nominal
TX Disable Deassert Time	toff_txdis		400	ms	Time from TX Disable bit cleared until optical output rises above 90% of nominal
RX Output Disable Assert Time	ton_rxdis		100	ms	Time from RX Output Disable bit set until RX output falls below 10% of nominal
RX Output Disable Deassert Time	toff_rxdis		100	ms	Time from RX Output Disable bit cleared until RX output rises above 90% of nominal
Squelch Disable Assert Time	ton_sqdis		100	ms	This applies to RX and TX Squelch and is the time from bit set until squelch functionality is disabled
Squelch Disable Deassert Time	toff_sqdis		100	ms	This applies to RX and TX Squelch and is the time from bit cleared until squelch functionality is enabled

## Memory Map

The memory is structured as a single address, multiple page approach. The address is given as A0xh. The structure of the memory is shown in Figure 18. The memory space is arranged into a lower, single page, address space of 128 bytes and multiple upper address space pages. This structure permits timely access to addresses in the lower page, e.g. Interrupt Flags and Monitors. Less time critical entries, e.g. serial ID information are available with the Page Select function. For a more detailed description of the QSFP+ memory map see the QSFP+ SFF-8436 Specification or the QSFP+ Memory Map document. DMI is not supported in this product.

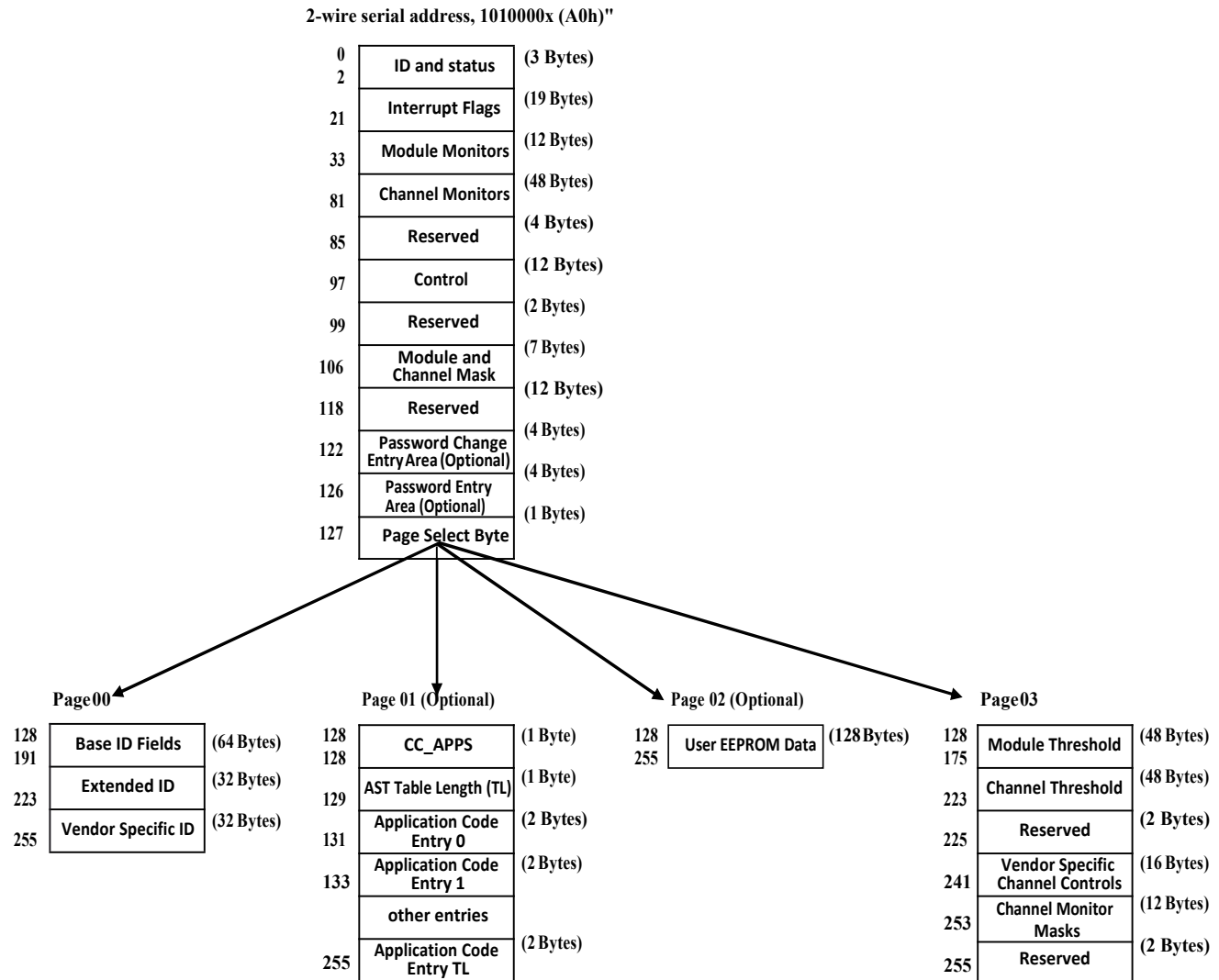

Figure 17. Two-Wire Serial Address A0h Page Structure

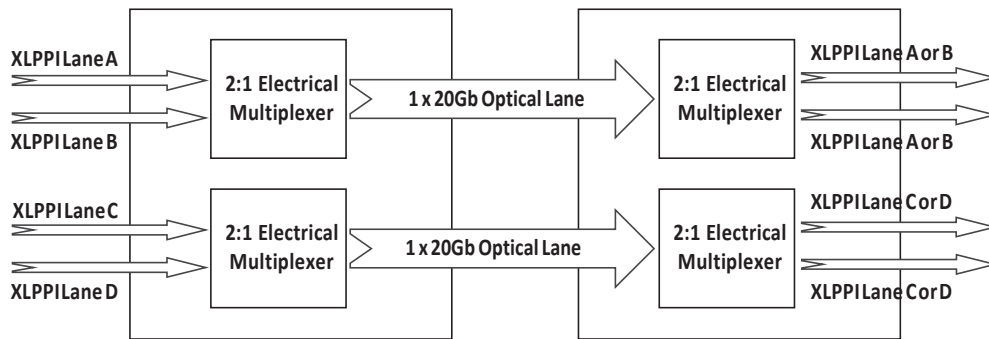

Figure 18. Transceiver Lane Ordering Limitations

## Lane Ordering

Care must be taken to reassemble XLPPi information at the host receiver due to uncertainty of phase alignment of Lane A and B between transmit and receive multiplexer stages. The transceiver will not assure XLPPi lane assignment end-to-end in order to keep complexity and power dissipation in the QSFP+ footprint to a minimum. Once end-to-end communication has been established and lane ordering established, lane assignment may change again each time the link is re-established, such as when TX LOS, RX LOS, or when module power cycling occurs.